

9800 Martel Road

Lenoir City, TN 37772

www.ps-engineering.com

PMA7000B



Document P/N 200-780-0004

Feb. 2004

Audio Selector Panel with Marker Beacon Receiver
High-fidelity Stereo Intercom
System Installation and Operation Manual

FAA-Approved TSO C50c, C35d

JAA-Approved JTSO C50c, 2C35d

Patented under one or more of the following; No. 5,903,277; 6,160,496 and 6,493,450

In certified aircraft, warranty is not valid unless this product is installed by an Authorized PS Engineering dealer.

PS Engineering, Inc. 2004 ©

Copyright Notice

Any reproduction or retransmittal of this publication, or any portion thereof, without the expressed written permission of PS Engineering, Inc. is strictly prohibited. For further information contact the Publications Manager at PS Engineering, Inc., 9800 Martel Road, Lenoir City, TN 37772. Phone (865) 988-9800, email avionics@ps-engineering.com.

Table of Contents

SECTION I GENERAL INFORMATION	1-1
1.1 INTRODUCTION	1-1
1.2 SCOPE.....	1-1
1.3 EQUIPMENT DESCRIPTION.....	1-1
1.4 APPROVAL BASIS -	1-2
1.5 SPECIFICATIONS	1-2
1.6 EQUIPMENT SUPPLIED.....	1-3
1.7 EQUIPMENT REQUIRED BUT NOT SUPPLIED.....	1-4
1.8 LICENSE REQUIREMENTS.....	1-4
SECTION II - INSTALLATION	2-1
2.1 GENERAL INFORMATION.....	2-1
2.1.1 SCOPE	2-1
2.1.2 CERTIFICATION REQUIREMENTS	2-1
2.2 UNPACKING AND PRELIMINARY INSPECTION	2-1
2.3 EQUIPMENT INSTALLATION PROCEDURES	2-1
2.3.1 COOLING REQUIREMENTS	2-1
2.3.2 MOUNTING REQUIREMENTS.....	2-1
2.3.3 AUDIO PANEL MOUNTING RACK INSTALLATION	2-1
2.3.4 AUDIO PANEL TRAY AND CONNECTOR ASSEMBLY	2-2
2.4 CABLE HARNESS WIRING.....	2-2
2.4.1 NOISE	2-3
2.4.2 EXISTING KMA-24 INSTALLATION.....	2-3
2.4.3 EXISTING PMA6000 INSTALLATIONS	2-3
2.4.4 POWER.....	2-3
2.4.5 COMMUNICATIONS PUSH-TO-TALK	2-4
2.4.6 AUDIO PANEL INTERFACE	2-4
2.4.7 COM 3 DUPLEX (TEL) FUNCTION FOR CELL PHONES	2-4
2.4.8 TRANSMIT INTERLOCK.....	2-5
2.4.9 "SWAP" MODE.....	2-5
2.4.10 BACKLIGHTING	2-5
2.4.11 UNSWITCHED INPUTS	2-5
2.4.12 PA MUTE (J1, PIN 18).....	2-6
2.4.13 PUBLIC ADDRESS FUNCTION (J2, PIN 18)	2-6
2.4.14 CONTROL OUTPUT (J2, PIN A).....	2-6
2.4.15 INTERCOM WIRING	2-6
2.4.16 PMA7000B INTERCOM EXPANSION (J2, PINS P, S, AND C)	2-7
2.4.17 PLAYBACK BUTTON INSTALLATION (J2, PIN 19- OPTIONS 1, ONLY).....	2-7
2.4.18 AUDIO MESSAGE ACKNOWLEDGE (J2, PIN W) OPTION 1 ONLY.....	2-7
2.5 MARKER BEACON INSTALLATION.....	2-8
2.5.1 MARKER ANTENNA INSTALLATION	2-8
2.5.2 EXTERNAL MARKER LIGHTS (MARKER VERSION).....	2-8
2.5.3 MIDDLE MARKER SENSE (MARKER VERSION).....	2-8
2.5.4 MARKER AUDIO INPUT (NON-MARKER VERSION).....	2-8
2.6 ADJUSTMENTS.....	2-8
2.7 COMMUNICATIONS ANTENNA INSTALLATION NOTES.....	2-9
2.7.1 HOOK SWITCHES	2-9
2.7.2 AUDIO ACTIVE OUTPUT	2-10
2.8 PMA7000B PIN ASSIGNMENTS	2-10
2.9 POST INSTALLATION CHECKOUT	2-11

PS Engineering
PMA7000B Series Audio Selector Panel and Intercom System
Installation and Operator's Manual

2.10 UNIT INSTALLATION 2-11

2.10.1 OPERATIONAL CHECKOUT 2-11

2.10.2 RECEIVER SENSITIVITY 2-12

2.11 CELLULAR INTERFACE CHECKOUT 2-12

2.12 INTERNAL RECORDER CHECKOUT (OPTIONAL)..... 2-12

2.13 DIGITAL ANNUNCIATION CHECKOUT (OPTIONAL) 2-12

2.14 FINAL INSPECTION..... 2-12

SECTION III OPERATION 3-1

3.1 SCOPE..... 3-1

3.2 POWER SWITCH (EMG-FAIL SAFE OPERATION) 3-1

3.3 MICROPHONE (XMT) SELECTION (ALL MODELS) 3-1

3.3.1 SWAP MODE (SWITCH FROM COM 1 TO COM 2 REMOTELY) 3-2

3.4 AUDIO SELECTOR (ALL MODELS) 3-2

3.4.1 SPEAKER AMPLIFIER 3-2

3.4.2 KEY "CLICK" 3-2

3.5 SPLIT MODE 3-2

3.5.1 SPLIT MODE ICS 3-3

3.6 INTERCOM OPERATION 3-3

3.6.1 INTELLI VOX® VOX-SQUELCH 3-3

3.6.2 INTERCOM VOLUME CONTROL 3-4

3.6.3 INTERCOM MODES 3-4

3.7 TELEPHONE MODE 3-5

3.8 MARKER BEACON OPERATION (IF PRESENT) 3-6

3.9 INTERNAL RECORDER SYSTEM (OPTION 1, 7)..... 3-6

3.9.1 OPERATION 3-6

3.10 AUDIO MESSAGING SYSTEM (OPTION 1)..... 3-7

3.10.1 CONCURRENT MESSAGES 3-7

SECTION IV- WARRANTY AND SERVICE 4-1

4.1 WARRANTY 4-1

4.2 FACTORY SERVICE..... 4-1

APPENDIX A EXTERNAL PTT HOOK UP A

APPENDIX B – PMA 7000B INSTALLATION DRAWING..... B

APPENDIX C BOTTOM CONNECTOR INTERCONNECT C

APPENDIX D TOP CONNECTOR INTERCONNECT D

APPENDIX E- INSTRUCTIONS FOR FAA FORM 337 AND CONTINUING AIRWORTHINESS E

9.1 INSTRUCTIONS FOR FAA FORM 337, AUDIO PANELS E

9.2 INSTRUCTIONS FOR CONTINUING AIRWORTHINESS, AUDIO SYSTEM..... E

APPENDIX F RTCA DO160C (EURO ED-14) ENVIRONMENTAL QUALIFICATION FORM ... F

CROSS REFERENCE FOR BENDIX/KING KMA26..... G

CROSS-REFERENCE FOR GMA340..... G

Revision History

Rev	By	Date	Change
1	GLP	Dec. 2002	Clarified the AirCell Guardian Interface, added patent number to cover
2	GLP	May 2003	Removed confusing part numbers, added Option 2 (No marker)
3	GLP	Dec 2003	Added cell phone interconnect, CNX80 interface, removed POTS interface. Added x-reference to KMA26 & GMA340
4	GLP	Feb. 2004	Clarify CNX80 interface, incompatible with Option 1

Section I GENERAL INFORMATION

1.1 INTRODUCTION

The PMA7000B represents the next step in cockpit audio control and intercommunications utility. Using proprietary *IntelliVox*® design, this unit eliminates the requirements for intercom squelch adjustments. The unit is designed for outstanding ergonomics and visually defined mode annunciation and selection.

Before installing and/or using this product, please read this manual completely. This will ensure that you will take full advantage of all the advanced features in the PMA7000B.

1.2 SCOPE

This manual provides detailed installation and operation instructions for the PS Engineering PMA7000B-series of Audio Selector Panel/Intercom Systems. This includes the following units:

<u>Model</u>	<u>Description</u>	<u>Part Number</u>
PMA7000B	Stereo Audio Selector Panel with Marker Beacon	7000B
Option 1 added to any 7000B	Digital Recorder and Aural Warning System (DRAWS) added	7000B-Opt 1
Option 2 on any system	Stereo Audio Panel Without Marker Beacon	7000B-Opt 2
Option 3 added to any system	Black bezel (no silver trim) Black Bezel (no silver trim) w/ DRAWS	7000B-Opt 3 7000B Opt-1, 3
Option 7	Digital Recorder Only (Raytheon Version)	7000B Opt 3, 7
Other options may be applied for exclusive use by specific aircraft manufacturers, under Type Certification. Call for information.		

Where the functions are identical to all units, it will be referred to herein as a PMA7000B. Otherwise, the applicable units will be specified.

1.3 EQUIPMENT DESCRIPTION

The PMA7000B-series is a state of the art audio isolation amplifier and audio selector that contains an automatic voice activated (VOX) intercom system. It can switch up to three transceivers (Com 1, Com 2 and Com 3) and six receivers (Nav 1, Nav 2, ADF, DME, MKR and AUX).

A duplex COM 3 mode (selectable at installation) allows the PMA7000B to act as an audio interface between aircraft headphone and microphones and specific aircraft approved (FAA/FCC) cellular telephone equipment.

Warning: Use of non-aviation approved cellular telephone equipment may be prohibited by regulation. PS Engineering is not responsible for unauthorized airborne use of cellular telephones. For airborne use, the PMA7000B must be interfaced with an approved system.

There are four unswitched inputs, available for traffic or EGPWS, autopilot disconnect, and/or radar altimeter warning.

Push buttons select the receiver audio source provided to the headphones. A SPR button allows the user to listen to the receiver(s) selected on the cabin speaker. Except for the unswitched inputs, all speaker audio is muted during transmit.

Push button switches selects one of the communication transceivers for the pilot and copilot position, and allows radio transmission. In "Split Mode" the PMA7000B has the ability to allow the pilot and copilot to operate different transceivers independently. The Com 3/TEL mode (selected at installation) allows the pilot to use the audio panel for duplex operation, such as with aviation-specific cellular telephones. External switches permit telephone operation for the copilot and passengers.

PS Engineering
PMA7000B Series Audio Selector Panel and Intercom System
Installation and Operator's Manual

A fail-safe mode connects the pilot headphone and microphone to COM 1 if power is removed for any reason, or if the power switch is placed in the Off (Fail-safe) position.

A six-station voice activated (VOX) intercom is included in the PMA7000B. This system has PS Engineering's exclusive *IntelliVox*® circuitry that eliminates manual adjustments. The system contains six separate VOX mic circuits, and only opens the microphone channel in use.

The intercom system incorporates pilot isolate and crew modes, two independent stereo music inputs with "Soft Mute," and flashing LED indicators for transmit indications. Intercom control is through two front panel-mounted volume knobs and 3-position mode switch. The concentric volume controls the intercom level for the pilot and copilot, while the outer knob controls the passenger intercom volume. Intercom squelch is automatic.

A 3-light Marker Beacon receiver is integrated in the PMA7000B. This provides the necessary Marker Beacon lights and audio indications necessary for an Instrument Landing System (ILS) approach.

1.4 APPROVAL BASIS -

TSO Approval.

The PMA7000B-series Audio Selector Panels are FAA approved under TSO C50c (Audio Amplifiers) and TSO C35d (Marker Beacon Receivers). In addition, they are approved by the Joint Airworthiness Authorities under JTSO C50C and JAR-TSO 2C35d.

All systems comply with relevant portions of EUROCAE RTCA MPS WG No. 7/70, DO-143 and (*Marker Beacon Receivers*), ED-14C/DO-160C (*Environmental Conditions and Test Procedures for Airborne Equipment*), ED12B/DO-178B (*Software Considerations for Airborne Equipment*) and ED- 18/DO-214 (*Audio Systems Characteristics and Minimum Operational Performance Standards for Aircraft Audio Systems*).

Operation is subject to the following conditions:

This device may not cause harmful interference.

This device must accept any interference received, including interference that may cause undesired operation.

1.5 SPECIFICATIONS

TSO COMPLIANCE	
<i>Marker Beacon:</i>	C35d, Class A
<i>Audio Selector/Intercom:</i>	C50c, Class A
APPLICABLE DOCUMENTS:	RTCA/DO-214 RTCA/DO-143 RTCA/DO-160C RTCA/DO-178B
ENVIRONMENTAL Qualifications:	A1D1/CA(MN)XXXXXXBBBBTBKXX
<i>Operating Temperature Range:</i>	-15° C to 55°C
<i>Altitude:</i>	Up to 50,000 feet in a non-pressurized area
DIMENSIONS:	Height: 1.3 in. (3.3 cm) Width: 6.25 in. (16.9 cm) Depth: 6.8 in. (17.3 cm)
WEIGHT (With Rack & Connectors):	1.5 lb. (0.54 kg)
POWER REQUIREMENTS (Including Internal Lighting):	
<i>Voltage:</i>	11 to 33 VDC
<i>Maximum Current:</i>	2.5 Amp (Externally protected by a 3A pull-type breaker)

PS Engineering
PMA7000B Series Audio Selector Panel and Intercom System
Installation and Operator's Manual

Audio Selector Specifications	
<i>Audio selector panel input impedance:</i>	510 Ω
<i>Input Isolation:</i>	-60 dB (min.)
<i>Speaker Muting:</i>	-60 dB (min.)
<i>Speaker Output (into 4 Ω) with no clipping</i> 14 VDC: 28 VDC:	3 Watts (min.) 10 Watts (min.)
<i>Receiver Inputs:</i>	9 (Com 1, Com 2, Com 3, Nav 1, Nav 2, ADF, DME, MKR, AUX)
<i>Unswitched Inputs:</i>	4
<i>Transmitter Selections:</i>	5 (Com 1, Com 2, Com 3 Com1/2, Com1/3)
<i>Speaker Impedance:</i>	4 Ω
<i>Headphone Impedance:</i>	150 – 1000 Ω
<i>Headphone Output:</i>	38 mW each headset, no clipping <1% THD
<i>Microphone Impedance:</i>	150 - 600 Ω
Intercom Specifications	
<i>Intercom Positions:</i>	6 places (with individual <i>IntelliVox</i> ® circuits)
<i>Music Inputs:</i>	2, (Independent, Stereo)
<i>Music Muting:</i>	>-30 dB "Soft Mute" when Com or intercom active.
<i>Distortion:</i>	<1% THD @ 38 mW into 150 Ω
<i>Mic Freq. Response, 3 dB:</i>	300 Hz - 6000 Hz
<i>Music Freq. Response, 3 dB:</i>	20 Hz - 18kHz
MARKER BEACON RECEIVER: (if equipped)	
<i>Frequency:</i>	75 MHz Crystal Controlled
<i>Sensitivity:</i> Low: High:	Capable of: (preset at factory for field application) 1000 μ Volts (Hard) (360 to 570 μ V soft) 200 μ Volts (Hard) (130 to 200 μ V soft)
<i>Selectivity:</i>	-6 dB at \pm 10 kHz -40 dB at \pm 120 kHz
<i>External Lamp Output:</i>	7.5 (\pm 4 VDC unloaded, at maximum brightness) VDC positive when active, max. current 125 mA
<i>MM Sense:</i>	Active high (4.5 \pm 1.0VDC)

1.6 EQUIPMENT SUPPLIED

1 ea. of the following units:

Model	Description	Part Number
PMA7000B	PMA7000B Audio Panel with Marker Beacon and Stereo intercom.	7000 ()
PMA7000B Opt 2	PMA7000B Audio Panel without Marker receiver	7000 Opt 2

PMA7000B Installation Kit: 250-007-0002

Description	Quantity	Part Number
PMA7000 installation rack assembly	1	120-430-0420
Top Molex Connector Shell w/key, 44 pin, key 4/5	1	120-425-4402
Bottom Molex Connector Shell w/key, 44 pin, key 7/8	1	120-425-4400
Gold Plated Crimp Pins	88	425-001-0002
4 40 X 7/16 screw w/nylon patch	4	475-440-0007
Grounding bar	1	430-007-0001
6-32 X 3/4 pan head Phillips screw	2	475-632-0038
6-32 Nut Flat	2	475-632-0003

PS Engineering
PMA7000B Series Audio Selector Panel and Intercom System
Installation and Operator's Manual

Installation Kit Description	Quantity	Part Number
6-32 Lock Nut	2	475-632-0004
Cable Clamp	1	625-001-0002
#6-32 x 1/2" Flat head Phillips screw	6	475-632-0012
#6-32 Clip Nut	6	475-630-0002
Parts identification sheet	1	002-250-7028
Pilot's Guide	1	202-070-0001.

1.7 EQUIPMENT REQUIRED BUT NOT SUPPLIED

- a) Circuit Breaker: 1 ea; 3 amp PULL TYPE REQUIRED for PMA7000B
- b) Speaker, 4 Ω
- c) Headphone Jacks (Stereo, as Required)
- d) Microphone Jacks (as Required)
- e) Headphones, 150 Ω (Stereo), up to 6 as required
- f) Microphones, up to 6 as required
- g) Marker Antenna (75 MHz, VSWR <1:1.5, and appropriate for the airspeed)
- h) Interconnect Wiring

1.8 LICENSE REQUIREMENTS

None

Section II - Installation

2.1 GENERAL INFORMATION

2.1.1 SCOPE

This section provides detailed installation and interconnection instructions for the PS Engineering PMA7000B-Series Audio Selector Panel/Intercom/ with internal Marker Beacon.

Please read this manual carefully before beginning any installation to prevent damage and post-installation problems. Installation of this equipment requires special tools and knowledge.

2.1.2 Certification Requirements

NOTE

The PMA7000B requires specialized knowledge and tools for an effective installation. An appropriately rated Certified Aircraft Repair Station **must** install this equipment in accordance with applicable regulations. PS Engineering, Incorporated warranty is not valid unless the equipment is installed by an authorized PS Engineering, Incorporated dealer. Failure to follow any of the installation instructions, or installation by a non-certified individual or agency will void the warranty, and may result in an **unairworthy** installation.

2.2 Unpacking and Preliminary Inspection

Use care when unpacking the equipment. Inspect the units and parts supplied for visible signs of shipping damage. Examine the unit for loose or broken buttons, bent knobs, etc. Verify the correct quantity of components supplied with the list in Section 1.6 (B). If any claim is to be made, save the shipping material and contact the freight carrier. Do NOT return units damaged in shipping to PS Engineering. If the unit or accessories show any sign of external shipping damage, contact PS Engineering to arrange for a replacement. Under no circumstances attempt to install a damaged unit in an aircraft. Equipment returned to PS Engineering for any other reason should be shipped in the original PS Engineering packaging, or other UPS approved packaging.

2.3 Equipment Installation Procedures

2.3.1 Cooling Requirements

Forced air-cooling of the PMA7000B is not required. However, the units should be kept away from heat producing sources (i.e. defrost or heater ducts, dropping resistors, heat producing avionics) without adequate cooling air provided.

2.3.2 Mounting Requirements

The PMA7000B must be rigidly mounted to the instrument panel of the aircraft structure and within view and reach of the pilot position(s). Installation must comply with FAA Advisory Circular AC 43.13-2A. The unit may be mounted in any area where adequate clearance for the unit and associated wiring bundle exist.

Avoid installing the unit close to high current devices or systems with high-voltage pulse type outputs, such as DME or transponders. Avoid running the interconnecting bundles near any high current wires.

2.3.3 Audio Panel Mounting Rack Installation

Remove the unit from the mounting tray by unscrewing the 3/32" hex-head screw that is in the center of the unit. Use caution to avoid hitting the photo-detector lens. Carefully slide the unit free of the tray. Set the unit aside in a safe location until needed. Install the tray using six clip nuts (475-630-0002), and six

FHP 6-32 x 1/2" screws (475-632-0012). The audio selector panel must be supported at front and rear of the mounting tray.

2.3.4 Audio Panel Tray and Connector Assembly

The unit connectors mate directly with the circuit boards in the PMA7000B. The connectors are a Molex crimp-type, and require the use of a Molex hand crimp tool, EDP P/N 11-01-0203, CR6115B (or equiv.). The connectors are mounted to the unit tray with #4-40 screws (475-440-0007), from the inside of the tray. Ensure that proper strain relief and chafing precautions are made during wiring and installation, using the cable clamp (625-001-0002). Secure the ground bar (430-007-0001), if desired using, #6-32 nuts (475-632-0003) and #6-32 lock nuts (475-632-0004).

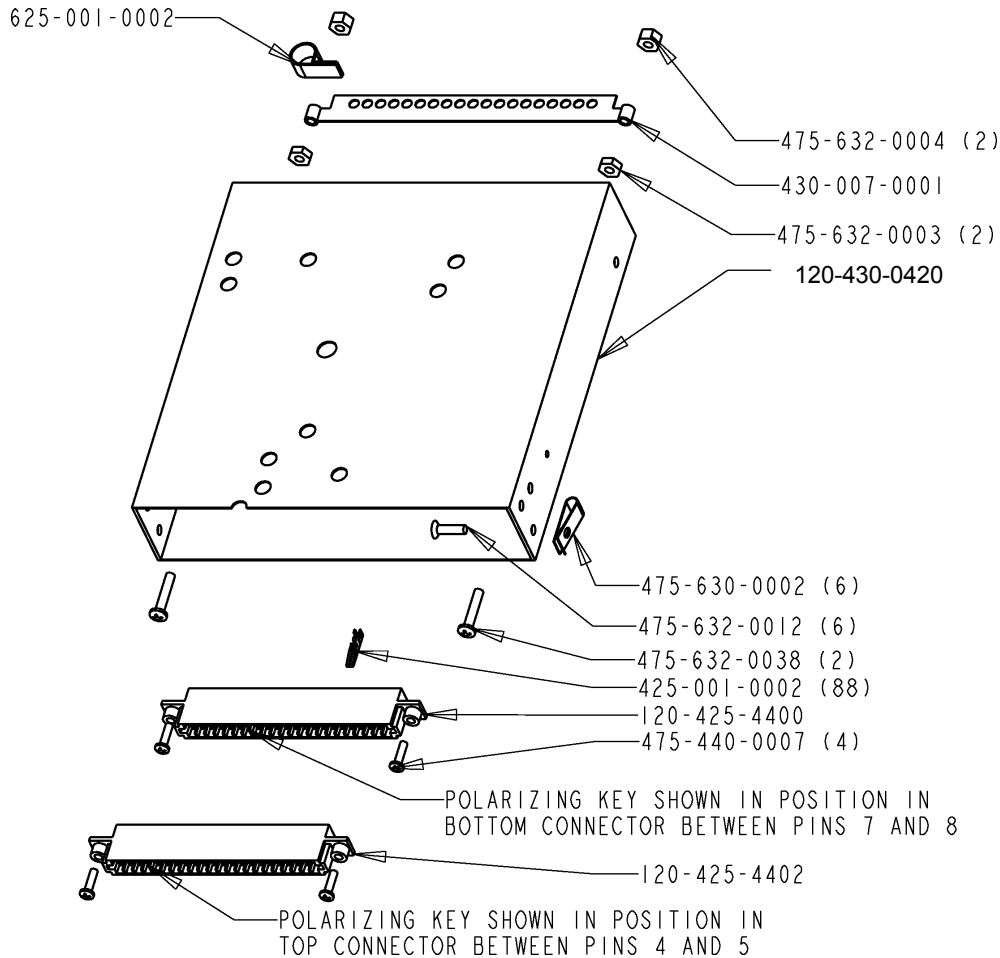

Figure 2-1 Audio Panel Tray Assembly Drawing

2.4 Cable Harness Wiring

Referring to the appropriate Appendix, assemble a wiring harness as required for the installation. All wires must be MIL-SPEC in accordance with current regulations. Two- and three-conductor shielded wire must be used where indicated, and be MIL-C-27500 or equivalent specification. Proper stripping, shielding and soldering technique must be used at all times. It is imperative that correct wire be used.

Refer to FAA Advisory Circular 43.13-2A for more information. Failure to use correct techniques may result in improper operation, electrical noise or unit failure. Damage caused by improper installation will void the PS Engineering warranty.

NOTE: PS Engineering can make a custom wiring harness for the intercom. Call 1-800-ICS-AERO or see www.ps-engineering.com for details.

2.4.1 Noise

Due to the variety and the high power of radio equipment often found in today's general aviation aircraft, there is a potential for both radiated and conducted noise interference.

The PMA7000B power supply is specifically designed to reduce conducted electrical noise on the aircraft power bus by at least 50dB. Although this is a large amount of attenuation, it may not eliminate all noise, particularly if the amplitude of noise is very high. There must be at least 13.8 VDC present at the bottom connector, pin 20, of the PMA7000B for the power supply to work in its designed regulation. Otherwise, it cannot adequately attenuate power line noise. Shielding can reduce or prevent radiated noise (i.e., beacon, electric gyros, switching power supplies, etc.) However, installation combinations can occur where interference is possible. The PMA7000B was designed in a RFI hardened chassis and has internal Electromagnetic Interference (EMI) filters on all inputs and outputs.

Ground loop noise occurs when there are two or more ground paths for the same signal (i.e., airframe and ground return wire). Large cyclic loads such as strobes, inverters, etc., can inject noise signals onto the airframe that are detected by the audio system. Follow the wiring diagram very carefully to help ensure a minimum of ground loop potential. Use only Mil Spec shielded wires (MIL-C-275000, or better). Under no circumstances combine a microphone and headphone wiring into the same shielded bundle. Always use a 2- or 3-conductor, shield wire as shown on the installation wiring diagram.

Radiated signals can be a factor when low level microphone signals are "bundled" with current carrying power wires. Keep these cables physically separated. It is very important that you use insulated washers to isolate the ground return path from the airframe to **all** headphone and microphone jacks.

Adding a high-performance audio control system, particularly in conjunction with high-performance active noise canceling headsets, cannot improve on older avionics that were designed for cabin-speaker use. PS Engineering makes no claim that the audio panel will provide a noise-free audio quality under all installation conditions, particularly with older avionics.

2.4.2 Existing KMA-24 Installation

If the installation replaces a KMA-24 (series -01, -02 or -03), the existing 44 pin connector can be used for the bottom connector of the PMA7000B tray as is, providing it is properly installed and wired. No other changes are required except for external marker lights (see Section 3.7.2 for details). The "key" in the existing connector must be located between pins 7 and 8. This connector will be used in the bottom connector position. (See Appendix for complete wiring harness details.)

The existing ground bus may be reused for radio shield connections, if it was constructed so it can be relocated to the PMA7000B tray.

2.4.3 Existing PMA6000 installations

In 28-Volt aircraft, the dropping resistor may be removed, however, the 2 Amp breaker should be changed to 3 Amp. If the old unit is stereo (PMA6000S or PMA6000MS), no rewiring is necessary except to add additional features.

2.4.3.1 Stereo PMA7000B installations into monaural PMA6000, PMA6000M.

Installations replacing PMA6000 or PMA6000M require re-wiring of the top connector to accommodate the stereo configuration. See appendixes for detailed interconnect information.

2.4.4 Power

The PMA7000B-Series are compatible with both 14 and 28 Volt DC systems. A two (2) Amp circuit breaker is required for 14 VDC installations, and a three (3) Amp breaker for 28 VDC aircraft. Power and ground wires must be a twisted #18 AWG pair. Connect airframe power ground to J1 (bottom connector) Pin Z only. No dropping resistors are required.

2.4.5 Communications Push-to-Talk

An important part of the installation is the PTT (Push-To-Talk) switches that allow the use of your aircraft communications radio for transmissions. There are three typical configurations that can be used. Select the case that best fits the installation. Only the person who presses their PTT switch will be heard over the radio. If the pilot and copilot both use the PTT, the only pilot position has access to the radio. The pilot position will have PTT control regardless of the mic selector switch or copilot PTT when the PMA7000B is in the OFF/EMG mode.

CASE I: PTT is built into both pilot and copilot yokes.

CASE II: PTT is in pilot yoke only. This configuration requires a modified external PTT switch plugged into the copilot's microphone jack. (See Appendix A). When the copilot's PTT is pressed, the intercom switches the microphone audio from pilot to copilot mic.

CASE III: No built in PTT. This requires two built in PTTs to be installed, or modified external PTT switches to be used. Modify external PTT as required. See Appendix A.

2.4.6 Audio Panel interface

The PMA7000B is designed to interface with standard aircraft avionics, and presents a 500 Ω receiver impedance. For best results, a twisted-shielded cable is recommended from the avionics audio source to the audio panel, with the shield grounded at the audio panel end.

Some avionics do not provide a separate audio low, and may introduce additional electrical noise into the system. For best results, connect the audio low from the audio panel to the radio ground, using one conductor of the twisted-shielded cable.

2.4.6.1 Speaker Load

The PMA7000-series contains a speaker amplifier. Some units with internal speaker amplifiers, such as the King Radio KX170-series, require a resistive load to prevent damage if their speaker amplifier is not used. Connect the speaker output from the unit to the load input on the PMA7000B (J1, pins 19 and L, 16 and M). The speaker load is 16 Ω , 3W.

2.4.7 Com 3 Duplex (TEL) Function for Cell Phones

As installed in the standard configuration, the PMA7000B Com 3 function operates conventionally. Pushing the Com 3 Xmt button places the receive audio from Com 3 in the headset and applies the pilot or copilot microphone to the Com 3 when the appropriate PTT is activated.

If J2, Pin J is connected to aircraft ground, the PMA7000B is forced into Com 3-Duplex mode. This mode is designed to operate with telecommunications systems, such as the AirCell Guardian 1000. Audio streams selected by hook switches are provided to the COM 3 output, the PTT for Com 3 is inactive, and audio from Com 3 is presented to the headset. This allows a telephone-like audio interface. The COM 3 input and output are compatible with aviation radios.

When Pin J is grounded, the PMA7000B is also compatible with many cellular telephones with hands-free headset interfaces. A 1/8" or 3/32" jack can be installed on the aircraft panel, and interfaces with the PMA7000B as shown: A patch cord (3/32" to 3/32") is available from PS Engineering under P/N 425-006-7026.

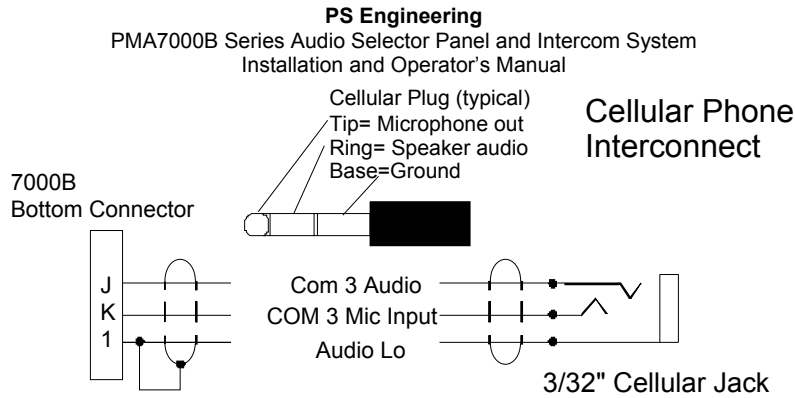

**For Duplex (cell phone) operation
Pin J of top connector MUST BE GROUNDED
This is a typical interconnect
PS Engineering does not guarantee
compatibility in all cases.**

Figure 2-2 Cellular telephone interface

Unauthorized use of unapproved cellular telephone devices in aircraft is subject to FCC enforcement action, which may include a \$10,000 fine per incident. PS Engineering, Inc. does not endorse using unapproved cellular telephone equipment in flight, and takes no responsibility for the user's action.

2.4.8 Transmit Interlock

Some communications transceivers use a transmit-interlock system. To fully utilize the Split Mode feature, this function must be disabled. Consult that manufacturer's installation manual.

2.4.9 "Swap" Mode

When a momentary, normally open, push-button switch is connected between pin 10 on the top connector and aircraft ground, the user can switch between Com 1 and 2 by depressing this switch without having to turn the mic selector switch. This yoke-mounted switch eliminates the need to remove your hands from the yoke to change transceivers. The transfer of TX indication from Com 1 to Com 2 shows that the swap has been initiated, there is no dedicated swap indicator.

2.4.10 Backlighting

The PMA7000B has an automatic dimming of the pushbutton annunciator LEDs and marker lamps controlled by a photocell. Control of the unit backlighting is through the aircraft avionics dimmer. Connect the dimmer control line to J1 pin D for 14 volt systems, and to J1 pin F for 28 volt systems. Pin E is light ground.

If an external dimmer control is **not** used, a constant low level back light illumination can be established for nighttime viewing. Pin D or F (depending on system voltage) must be tied to power (J1, pin 20) for the back lighting system to work. The photocell mounted in the unit face will automatically adjust the intensity of the push-button annunciator LEDs.

2.4.11 Unswitched inputs

J1, pins T, 17, U and X are unswitched, unmuted inputs. These inputs are presented to the pilot and copilot regardless of the audio configuration, and will always mute the entertainment inputs. These 510Ω inputs can be used for altimeter DH audio, GPS waypoint audio, autopilot disconnect tones, air-to-ground (Flite-fone) telephone ringer or any other critical audio signal. This input is not related to the cellular telephone interface. NOTE: These inputs are fixed (1:1), and any audio level adjustments must be made at the input source.

2.4.12 PA Mute (J1, Pin 18)

Pin 18 of J1 is a TTL logic output that is pulled low during PTT operation. This serves as an input to external public address system to prevent feedback during transmissions.

2.4.13 Public Address Function (J2, Pin 18)

By connecting the top connector (J2), Pin 18 to ground, the pilot's microphone audio is placed on the cabin speaker output. When the pilot's PTT is activated, his voice is heard over the speaker. The copilot can continue to use the selected com.

We recommend installing a toggle switch to connect the cabin speaker output (pin W, bottom connector) to a rear or public address speaker instead of the cockpit speaker close to the pilot. This will prevent feedback.

2.4.14 Control Output (J2, Pin A)

Pin A of the top connector is pulled to ground whenever the AUX button is depressed. This serves as a control line for external devices, such as an entertainment system that the pilot wishes to control.

This could be used in conjunction with a PA to control J2, Pin 18, as well as an external relay to change to the cabin speaker from the cockpit.

This pin can also be used to control passenger Karaoke Mode, by connecting to pin V of the J2, or as a copilot hook switch Pin L of J2, or passenger hook switch pin M, J2.

2.4.15 Intercom wiring

The top connector (J2) is for the intercom and additional functions. See Appendix for intercom connection configurations. It is critical to the proper operation of this system to have this connector wiring made in accordance with these diagrams. Use 2- and 3-conductor, MIL-spec cable as shown. Connect the shields at the audio panel end only, and tie to the audio low inputs as shown.

NOTE: The top connector harness can be custom made by PS Engineering, Inc. Simply call the factory and obtain a wire harness work-sheet. The harness will be made to your specifications and fully functionally tested. All hardware is included.

2.4.15.1 Entertainment Input

The PMA7000B has two INDEPENDENT music inputs. Entertainment input number 1 is J2 pins 15 (left channel) and 16 (right channel), WRT pin T, and is provided to the pilot and copilot. Entertainment number 2 is provided to the passengers at all times.

Entertainment 1 and 2 must be connected together in order for all positions to hear the same music source. We recommend installing a DPDT switch to allow isolation of the music sources if desired.

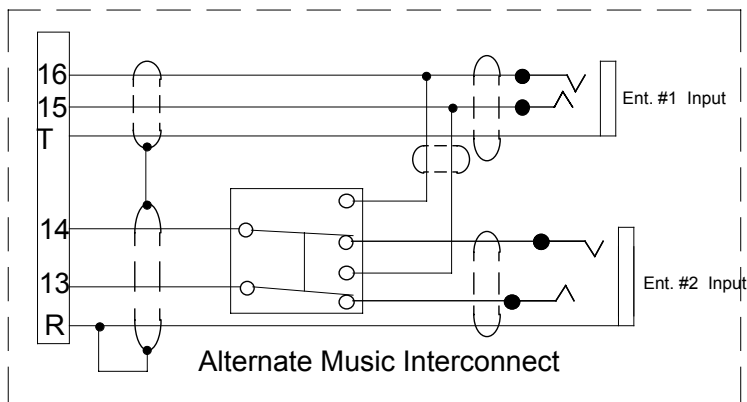

NOTE: Use the low level output of any additional entertainment device to connect to the audio panel. Maximum signal level is **2 VAC p-p**. **DO NOT** use a speaker-level output, this will cause internal damage in the audio panel.

2.4.15.1.1 Entertainment muting

The PMA7000B-system incorporates a "Soft Mute" system. This will mute the entertainment devices during ICS or radio conversation.

Any signal appearing in the unswitched audio inputs will always mute the entertainment sources, even though the passengers may not hear the audio tone itself.

Caution: Local oscillators and internal signals from entertainment equipment can cause undesired interference with other aircraft systems. Before takeoff, operate the entertainment devices to determine if there is any adverse effect within the aircraft systems. If any unusual operation is noted in flight, immediately switch off the entertainment devices.

All additional entertainment devices must be switched off for both takeoff and landing.

2.4.15.1.2 Entertainment 2 Mute (Pin V)

The ICS button on the PMA7000B controls the muting ("Karaoke mode") of entertainment source #1.

Connecting J2 pin V to ground through a SPST switch places the entertainment #2 music source into the Karaoke Mode. In this mode, incoming music and intercom conversation will not mute the music for the passengers' intercom net. This allows uninterrupted music during casual conversation and at times when radio communications are of lesser importance.

See section 2.4.14 for alternative connection.

2.4.16 PMA7000B Intercom expansion (J2, Pins P, S, and C)

The PMA7000B contains a 6-place intercom. In applications where more intercom positions are needed, PS Engineering can provide intercom expansion units, such as the IntelliPAX, part number 11606, 11606R, etc. These can add up to six additional stereo intercom stations, plus independent music input. Interface to the expansion unit is through J2, pins P (audio input from expansion unit), S (audio output to expansion unit) and C (9 VDC expansion power).

2.5 Playback and DRAWS (Digital Recorder Aural Warning System) Options

The PMA7000B is available with optional recording capability. Option 1 (DRAWS) contains a playback function, and aural warnings (see table below). **NOTE: This should be requested at time of order; it cannot be retrofitted.**



Option 1 (DRAWS) is not compatible with the CNX80 audio active function. If compatibility is desired, contact PS Engineering at (865) 988-9800 or support@ps-engineering.com. See section 2.8.2.

2.5.1 Playback button Installation (J2, Pin 19- Options 1, 7, ONLY)

To activate the Recording System playback, a momentary push button switch is required. This switch can be located anywhere in cockpit convenient to the pilot's reach. The switch must be connected to pin 19 of J2 of the PMA7000B, and ground

2.5.2 Audio Message Acknowledge (J2, Pin W) Option 1 Only

The audio message installation requires inputs from an external annunciator, such as an Electronics International engine gage system. A falling edge (input pulled low) when applied to the appropriate pin of the connector will cause the message to be played, repeating every two seconds, until the acknowledge ("ACK") button is pushed.

PS Engineering
PMA7000B Series Audio Selector Panel and Intercom System
Installation and Operator's Manual

Install the “ACK” button in a location convenient to the pilot and copilot position. This switch is a momentary SPST switch between J2 Pin W and ground.

The following table contains information regarding various inputs.

Function	EGT or CHT	Fuel Flow or Level	Oil Pressure or temperature	Volt/ Amp	RPM	Manifold Pressure
PMA7000B Pin	Z	22	Y	21	X	20
Message Number	1	2	3	4	5	6
Message Text	“Check temperature”	“Check fuel”	“Check oil”	“Check battery”	“Check engine speed”	“Check boost”

NOTE: PS Engineering can only provide input information at this time. Approval basis is the responsibility of the installer. Contact PS Engineering for more information.

2.6 Marker Beacon Installation

The marker beacon receiver is an option included in the PMA7000B. Non-marker (PMA7000) units can provide audio interface with the external receiver (see section 2.5.4).

2.6.1 Marker Antenna Installation

A marker beacon antenna, appropriate to the type and speed of the aircraft, is required (not included). Refer to aircraft and antenna manufacturer's installation instructions, as well as AC43.13-2A (or later revision), Chapter 3, for information on proper antenna installation techniques. The marker beacon antenna must be mounted on the bottom of the aircraft.

2.6.2 External Marker Lights (Marker version)

For installations that require external marker beacon lights, there are three outputs that can drive 12-Volt lamps only. The external output lamps are driven high (typically +9 VDC \pm 1.5 VDC unloaded, at MAX brightness) when active. Maximum source current per lamp is 125 mA. Voltage varies with photocell dimming.

2.6.3 Middle Marker Sense (Marker version)

A Middle Marker Sense output signal is available from the 7000B to flight control systems. This function will not operate during the test mode. This output will go to +4.5 VDC (\pm 1.0 VDC) when a valid Middle Marker signal is received. This output is J1, pin 2.

2.6.4 Marker Audio Input (non-marker version)

If using an external marker receiver, the audio input is J1, pin 21 (MKR input).

2.7 Adjustments

The PMA7000B is factory adjusted to accommodate the typical requirements for most aircraft configurations. There are five adjustments however, that will allow the installer to tailor the specific functions.

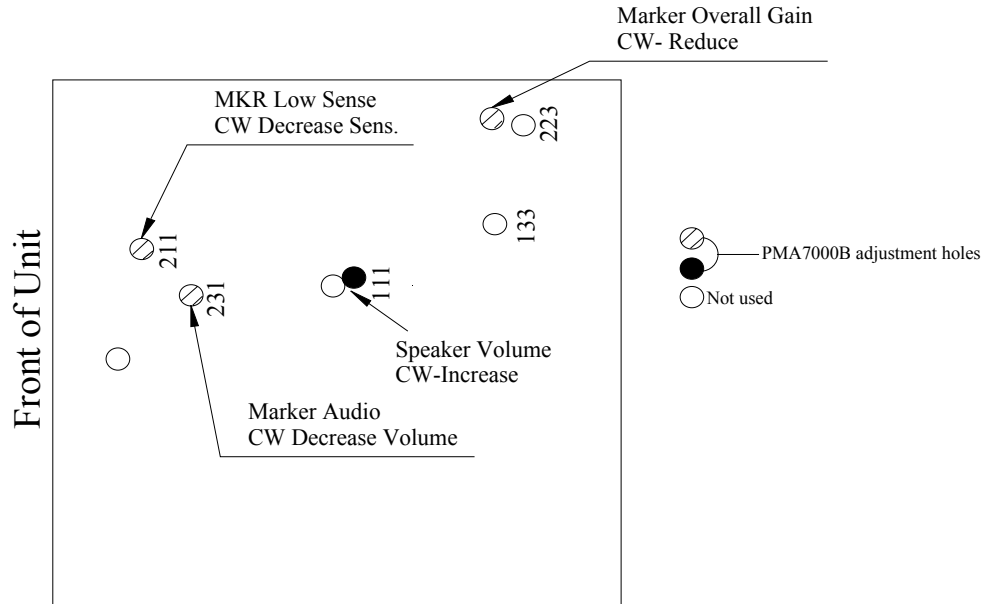

Figure 2-3- PMA7000B Adjustments

2.8 Communications Antenna Installation Notes

For best results while in Split Mode, it is recommended that the one VHF communications antenna is located on the top of the aircraft while the other communications antenna is installed on the bottom. Any antenna relocation must be accomplished in accordance with AC 43.13-2A, aircraft manufacturers' recommendations and FAA-approved technical data.

Warning:

It is probable that radio interference will occur in the split mode when the frequencies of the two aircraft radios are adjacent, and/or the antennas are physically close together. **PS Engineering makes no expressed or implied warranties regarding the suitability of the PMA7000B in Split Mode.**

2.8.1 Hook Switches

While the Com 3 button acts as the hook switch for the pilot, additional hook switches must be installed to have full access to the cellphone system. The copilot hook switch is a SPST switch that connects pin L of J2 on the PMA7000B to ground to place the copilot mic audio on the Com 3 audio in duplex mode for cellphone operation.

PMA7000B J2, pin M is the passenger hook switch. Install a SPST switch in a location adjacent to each passenger headset where cellphone use is desired. When pin M is connected to ground through any switch, the passenger microphones are all on the Com 3/duplex system.

The hook switches are not active or required unless the audio panel is in Com 3 /Duplex mode, with pin J, J2 grounded.

The wireless communication "tel" system utilizes an intercom loop. Therefore, any time the cellphone is in use from the pilot or copilot side, pilot and copilot will lose intercom capability. In the ALL mode, when the passengers' activate the cell phone, the pilots will have intercom, and continue to hear and transmit over the avionics normally. However the passengers will not have intercom, because they are on the telephone.

See section 2.4.14 for alternative connection for the hook switches.

2.8.2 Audio Active Output (Not available with Option 1-DRAWS)



Pin 20 on the top board (and PA Mute Pin 18 on the bottom board) should be connected to Apollo CNX80 for audio message prioritization, refer to CNX80 installation manual for details.

Audio Active Out is available on units with serial number above B01479-C01489 (or at least a “C” in the top board serial number-second set of numbers), without Option 1. For compatibility with Option 1, contact the PS Engineering factory at 865-988-9800, or support@ps-engineering.com.

2.9 PMA7000B Pin assignments

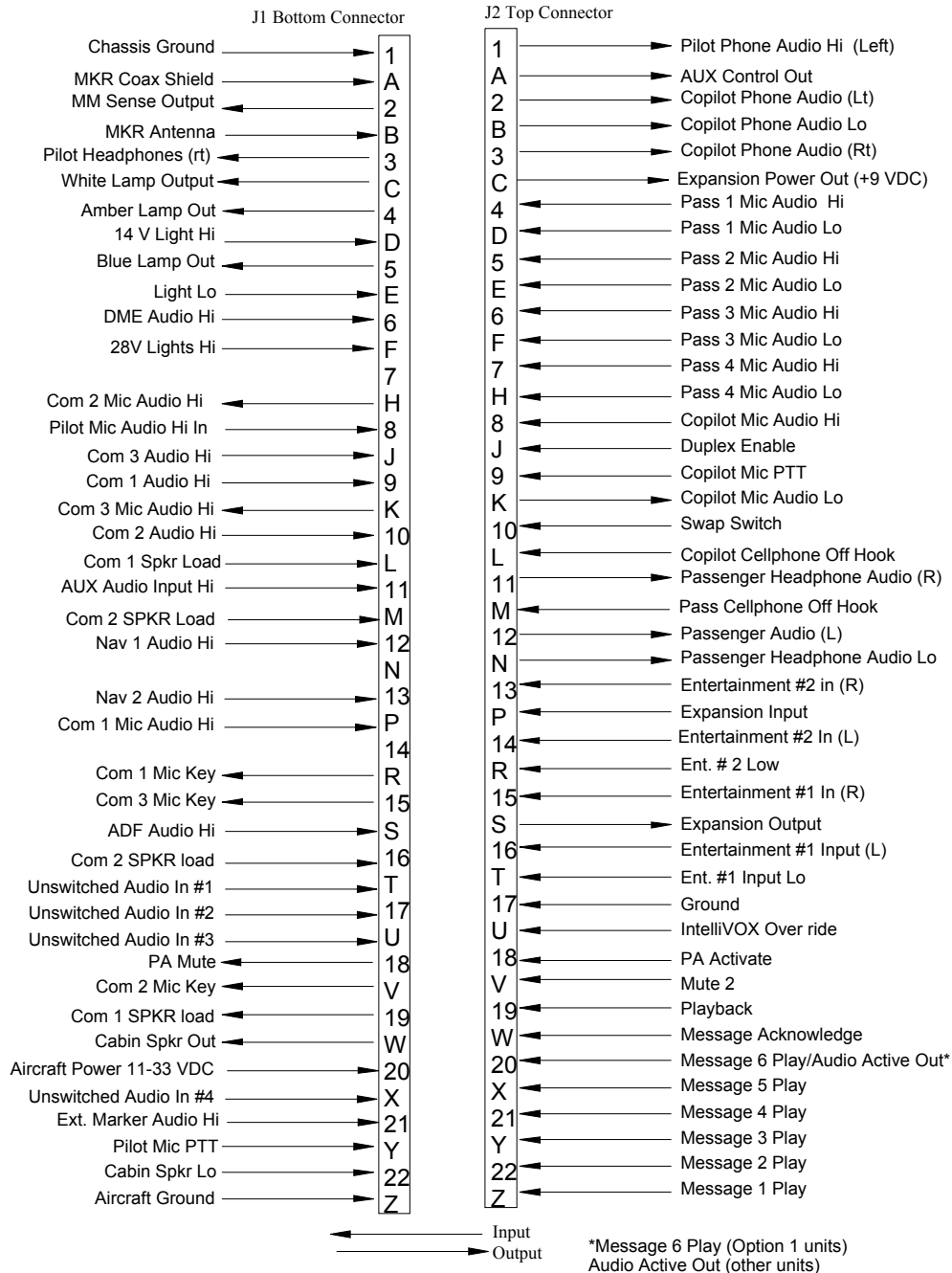

2.10 Post Installation Checkout

After wiring is complete, verify power is ONLY on pin 20 of the J1 (bottom connector), and airframe ground on bottom connector pin Z. Failure to do so will cause serious internal damage and void PS Engineering's warranty.

2.11 Unit Installation

To install the PMA7000B, gently slide the unit into the mounting rack until the hold-down screw is engaged. While applying gentle pressure to the face of the unit, tighten the 3/32" hex-head in the center of the unit until it is secure. DO NOT OVER TIGHTEN.

Warning: Do not over-tighten the lock down screw while installing the unit in tray.
Internal damage will result.

2.11.1 Operational Checkout

NOTE: The *IntelliVox*® is designed for ambient noise levels of 80 dB or above. Therefore some clipping may occur in a quiet cabin, such as without the engine running, in a hangar. This is normal.

1. Apply power to the aircraft and avionics.
2. Plug headsets into the pilot, copilot, and occupied passenger positions.
3. Verify fail-safe operation by receiving and transmitting on com 1 from the pilot position, with the audio panel power off. The Com audio will be present in the right ear cup only.
4. Switch on the unit by pressing the volume (VOL) knob.
5. Check intercom operation.
6. Push the Com 1 Xmt select button (lower row).
7. Verify that both of the **Com 1** buttons light. Verify that transmit button LED (Light Emitting Diode) near the mic selector is not blinking. If the LED is blinking, stop testing and troubleshoot the microphone PTT installation.
8. Verify proper transmit and receive operation from the copilot position, noting that the copilot PTT switch allows proper transmission on the selected transceiver. Verify that the Com 1 Xmt button blinks when transmitting.
9. Verify that pushing the **COM 2** button causes the button to illuminate, and the Com 2 receiver to be heard. Verify operation on Com 1 from the pilot position.
10. Repeat for Com 2 and standard Com 3, (if installed).
11. Press and hold the Com 1 Xmt button. While holding the Com 1 button, press the Com 2 Xmt button. This places the unit in "split Mode;" Verify that the pilot can transmit and receive on Com 1, while the copilot transmits and receives on Com 2.
12. If the audio panel is installed with J2, pin J grounded, it is configured for duplex operation on Com 3. Verify that the pilot headset is connected to the cellular telephone system (if installed). Verify that by using the pilot side PTT, the pilot can transmit on the other selected radio (Com 1 or Com 2). Verify that the Com 3 Xmt LED blinks at about twice the rate of com 1, to indicate a duplex mode. The copilot has radio transmit capability in Com3 duplex mode, on the selected Com (1 or 2). However, he will have Com 3 capability if the copilot hook switch is grounded.
13. Verify proper operation of all receiver sources by selecting them using the appropriate button. The button illuminates to show which source is in use.
14. Push the SPR button. Verify that all selected audio is heard in the cockpit speaker. Verify that the audio mutes when the mic is keyed.
15. Verify that the appropriate LED in the lower right side blinks when either push to talk is keyed.
16. Verify proper Intercom system operation in the **ALL**, **ISO** and **CREW** modes (see Table 3-1).

17. Verify that the audio selector panel system does not adversely affect any other aircraft system by systematically switching the unit on and off, while monitoring the other avionics and electrical equipment on the aircraft.

2.11.1.1 Marker Checkout

1. Connect a ramp generator at the antenna end of the marker coax. With the unit under test in HI sensitivity, verify that a 160 μ V, modulated 95% with 1300 Hz, signal will illuminate the amber (M) marker light, and that marker audio is present in the headphones when the Marker Audio (M) push-button has been depressed. Select SPR for speaker to verify marker audio availability on the cabin speaker. Verify that the white (I) and blue (O) lights will illuminate within \pm 3dB of the amber lamp, with 3000 HZ and 400 Hz applied, respectively.
2. Repeat with the unit in LOW sensitivity, with 430 μ Volts applied.
3. Connect the marker antenna and verify proper operation.

2.11.2 Receiver Sensitivity

Although the receiver meets FAA TSO-C35d sensitivity specifications, the sensitivity has been adjusted to meet real world requirements (150 μ V and 430 μ V, soft). This will usually eliminate the need for the avionics shop to reduce the sensitivity in the field so as to prevent early detection of the marker beacons. If your particular installation requires more or less sensitivity, see adjustment section 2.6, and figure 2-1.

2.12 Cellular Interface Checkout

When a wireless telecommunication system is installed and the unit configured for duplex, a dial tone will appear in the headset of the pilot when the COM 3 Xmt selector activated. In "ALL" intercom mode, a dial tone will be heard whenever the copilot or passenger's hook switch is closed.

2.13 Internal Recorder Checkout (Optional)

With headset plugged into pilot's side jacks, tune COM 1 to local frequency, such as FSS or ATC ground.

Select Com 1 on mic selector switch, and record at least five incoming radio transmissions.

This audio should only appear in the pilot's headset, and only be incoming transmissions from the transceiver selected in the mic select switch. Depress the panel or yoke mounted playback switch, and verify that messages play, in the order received. Repeat for COM 2, and COM 3 (if installed).

2.14 Digital Annunciation Checkout (Optional)

If interfaced with an annunciation system, verify that all alert messages play at the appropriate time, and that they are silenced by the "ACK" button.

2.15 Final Inspection

Verify that the wiring is bundled away from all controls and no part of the installation interferes with aircraft control operation. Move all controls through their full range while examining the installation to see that no mechanical interference exists. Verify that the cables are secured to the aircraft structure in accordance with good practices, with adequate strain relief. Ensure that there are no kinks or sharp bends in the cables and coaxial cables. Verify that the cables are not exposed to any sharp edges or rough surfaces, and that all contact points are protected from abrasion.

Complete log book entry, FAA Form 337, weight and balance computation and other documentation as required. Sample text for FAA Form 337, and instructions for continuing airworthiness can be found in Appendix F.

Return completed warranty registration application to PS Engineering.

Section III OPERATION

GENERAL INFORMATION

3.1 SCOPE

This section provides detailed operating instructions for the PS Engineering PMA7000B, Audio Selector Panel/Intercom Systems. Please read it carefully before using the equipment so that you can take full advantage of its capabilities.

This section is divided into four sections covering the basic operating areas of the PMA7000B systems. They are Audio Selector, Transceiver Selection, Intercom, and Marker Beacon Receiver (Marker version only).

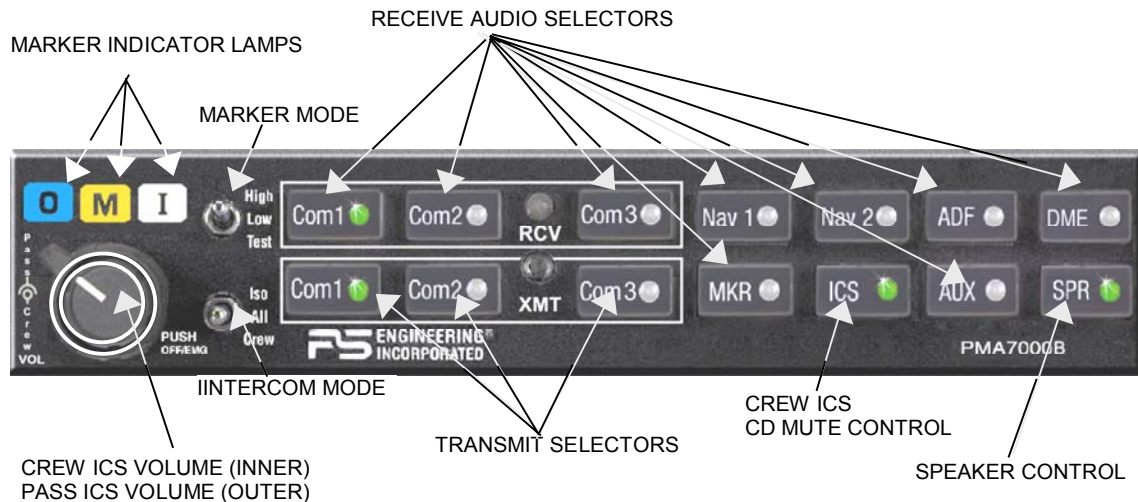

Figure 3-1 PMA7000B controls

3.2 Power Switch (EMG-Fail Safe Operation)

Unit power is turned on and off by pushing the volume knob. In the OFF or "EMG" position, the pilot is connected directly to Com 1. This allows communication capability regardless of unit condition. Any time power is removed or turned OFF, the audio selector will be placed in the fail-safe mode.

The power switch also controls the audio selector panel functions, intercom and marker beacon receiver.

3.3 Microphone (XMT) Selection (All models)

There are six pushbuttons associated with the communications transceivers. The lower buttons control which transceiver is selected for transmit.

The PMA7000B gives priority to the pilot's PTT. If the copilot is transmitting, and the pilot presses his PTT, the pilot's microphone will be heard over the selected com transmitter.

The PMA7000B-Series has an automatic selector mode. Audio from the selected transceiver is automatically heard in the headsets and speaker (if selected). You can check this function by switching from COM 1 to COM 2 and watch the selected audio light on the selector change from COM 1 to COM 2. This ensures the pilot will *always* hear the audio from the transceiver he is transmitting on.

When switching from COM 1 to COM 2, while COM 2 audio had been selected, Com 1 audio will continue to be heard. This eliminates the pilot having to switch Com 1 audio back on, if desired.

When switching from COM 1 to COM 2 while Com 2 has NOT been selected, Com 1 audio will be switched off. In essence, switching the mic selector will not effect the selection of Com receiver audio.

When the duplex enable, or TELEPHONE mode is implemented during installation, Com 3 becomes the "TEL" position. This is the pilot's "hook" switch, when the system is interfaced to an appropriate approved wireless telecommunication system, such as the AirCell system. Selecting Com 3 for transmit places the pilot microphone and headphones on the cellphone. The pilot PTT will switch the pilot mic to the other selected com transceiver, and allow continued aircraft communications to continue.

The copilot will also be able to transmit on the other selected radio with his PTT as well.

NOTE: Placing the mic selector switch in the COM 3 –TEL– mode will disable pilot and copilot intercom, as the intercom circuit is transferred to the telephone use. In crew or ISO mode, placing the switch in TEL mode removes the passengers access to the telephone.

3.3.1 Swap Mode (Switch from Com 1 to Com 2 remotely)

With a yoke mounted, momentary switch, the pilot can change from the current Com transceiver to the other by depressing this switch. To cancel "Swap Mode," the pilot may either press the yoke mounted switch again, or select a different Com with the XMT buttons. .

3.4 Audio Selector (All models)

Receiver audio is selected through seven momentary, push-button, backlit switches. You will always hear the audio from the transceiver that is selected for transmit.

The users can identify which receivers are selected by noting which of the green switch LEDs are illuminated. Push buttons labeled **Nav 1**, **Nav 2**, **MKR** (Marker), **ADF**, **DME**, **AUX** (auxiliary), and **SPR** (Speaker) are "momentary type switches. When one of these buttons is pressed, be active, and the LED will illuminate. Press the switch again and it be in the "off" position and remove that receiver from the audio.

3.4.1 Speaker Amplifier

The "SPR" in the push-button section stands for speaker. This switch will place all selected audio on the cockpit speaker when this switch is selected. NOTE: Except for the unswitched audio, the speaker amplifier is not active in the "Split Mode."

Unswitched audio, (autopilot disconnect, altimeter warning, etc.) will come through the speaker regardless of the speaker button position.

3.4.1.1 Public Address Function

To access PA function, a switch is installed to connect the top connector, pin 18, to ground. This places the *pilot* microphone on the speaker output (Pin W) when the PTT is pushed. The copilot can continue to use the selected com radio.

We recommend that the switch transfer the audio from the cockpit speaker to a cabin speaker for public address. This will prevent feedback.

3.4.2 Key "Click"

The PMA7000B is equipped with a "click" function that provides an aural feedback to the user in addition to the tactile button push. This sound can be enabled or disabled by simultaneously holding the COM 1 and COM 2 buttons in for at least 5 seconds. Any person hearing the radios will also hear the key click.

Allow at least 20 seconds between turning the key click on and off.

3.5 Split Mode

The split mode can be activated at any time by pressing the desired combination of XMT buttons. For instance, to activate a Com 1/Com 2 split, press and hold the Com 1 button, and then press the Com 2 button while holding the Com 1 button. This places the pilot on Com 1 and the Copilot on Com 2.

Split mode for Com 3 is possible with pilot on Com 1, copilot on Com 2 or 3, if telephone is not enabled.

Pilot on Com 2 or Com 3 and Copilot on Com 1 is not possible.

Note:

Due to the nature of VHF communications signals, and the size constraints in general aviation aircraft, it is probable that there will be some bleed-over in the Split mode, particularly on adjacent frequencies.
PS Engineering makes no warranty about the suitability of Split Mode in all aircraft conditions.

Note: Split Mode does not turn off other (Nav, ADF, etc.) selected audio to **pilot**. However, the copilot will only hear the selected communications receiver.

3.5.1 Split Mode ICS

In split mode, the pilot and copilot are usually isolated from each other on the intercom, simultaneously using their respective radios. Depressing the **ICS** button in Split Mode will activate VOX intercom between the pilot and copilot positions. This permits intercommunication when desired between the crew. Pressing the ICS button again disables this crew intercom function.

3.6 Intercom Operation

3.6.1 IntelliVox® VOX-Squelch

No adjustment of the *IntelliVox*® squelch control is necessary. There is no field adjustment. Through three individual signal processors, the ambient noise appearing in all six microphones is constantly being sampled. Non-voice signals are blocked. When someone speaks, only their microphone circuit opens, placing their voice on the intercom.

The system is designed to block continuous tones, therefore people humming or whistling in monotone may be blocked after a few moments.

For consistent performance, any headset microphone **must** be placed within ¼-inch of your lips, preferably against them. (ref: *RTCA/DO-214, 1.3.1.1 (a)*).

It is also a good idea to keep the microphone out of a direct wind path. Moving your head through a vent air stream may cause the *IntelliVox*® to open momentarily. This is normal.

The *IntelliVox*® is designed to work with normal aircraft cabin noise levels (70 dB and above). It loves airplane noise! Therefore, it may not recognize speech and clip syllables in a quiet cabin, such as in the hangar, or without the engine running. This is normal.

For optimum microphone performance, PS Engineering recommends installation of a Microphone Muff Kit from Oregon Aero (1-800-888-6910). This will not only optimize VOX performance, but will improve the overall clarity of *all* your communications.

Table 3-1 Mic Muff™ Part Numbers

Manufacturer	Model	Mic Muff™ Part Number
Bose	Dynamic	90010
	Electret	90015
	M87 Dynamic	90020
David Clark	H10-30	90010
	H10-20, H10-40	90015
	H10-13.4	90015
Lightspeed	15K & 20K	90015
Peltor	7003	90010
	7004	90015
Pilot	11-20 & 11-90	90015
Sennheiser		90015
Telex	Airman 750	90015
	AIR3000	90010

3.6.2 Intercom Volume Control

The inner volume control knob adjusts the loudness of the intercom for the pilot and copilot. It has no effect on selected radio levels, music input levels or passengers' volume level.

The outer volume control knob controls intercom volume or the passengers. It has no effect on radio or music levels.

Adjust the radios and intercom volume for a comfortable listening level. Most general aviation headsets today have built-in volume controls; therefore, volume also can be further adjusted at the individual headset.

3.6.2.1 Mono headsets in Stereo Installation

All passenger headsets are connected in parallel. Therefore, if a monaural headset is plugged in to a PMA7000B Stereo installation, one channel will be shorted. Although no damage to the unit will occur, all passengers will lose one channel, unless they switch to the "MONO" mode on the headset. PS Engineering modifies headsets to add stereo capability, using high-fidelity speakers. Contact factory for details.

3.6.3 Intercom Modes

The lower switch on the left side is a 3-position mode switch that allows the pilot to tailor the intercom function to best meet the current cockpit situation. The description of the intercom mode function is valid only when the unit is not in the "Split" mode. Then, the pilot and copilot intercom is controlled with the ICS button.

ISO: (Up Position): The pilot is isolated from the intercom and is connected only to the aircraft radio system. He will hear the aircraft radio reception (and sidetone during radio transmissions). Copilot will hear passengers' intercom and Entertainment 1, while passengers will hear copilot intercom and Entertainment 2. Neither will hear aircraft radio receptions or pilot transmissions.

ALL: (Middle Position): All parties will hear the aircraft radio and intercom. Crew will hear Entertainment 1, passengers will hear Entertainment 2. During any radio or intercom communications, the music volume automatically decreases. The music volume increases gradually back to the original level after communications have been completed.

CREW (Down Position): Pilot and copilot are connected on one intercom channel and have exclusive access to the aircraft radios. They may also listen to Entertainment 1. Passengers can continue to communicate with themselves without interrupting the Crew and also may listen to Entertainment 2.

Anytime the PMA7000B is in either the COM 1/COM 2, COM 2/COM 1 ("Split Mode"), the pilot and copilot intercom is controlled with the ICS button. The passengers will maintain intercommunications, but never hear aircraft radios.

3.6.3.1 Entertainment Input

The audio selector panel has provisions for two separate entertainment input devices. Music 1 feeds the pilot and copilot positions. They operate independently in the PMA7000B. The volume control does not affect the music level.

While in the ISO (Isolate) mode, the copilot will hear Entertainment 1 while the four passengers will hear Entertainment #2. The pilot will hear entertainment 1, at a muted level. In normal operation, whenever a person speaks, or if the aircraft radio becomes active, the music will automatically mute and then will gradually return to the original listening level when the intercom or radio conversation ceases.

When in the ALL mode, pilot and copilot will hear Entertainment 1 input while all passengers will hear the Entertainment 2 source. While in the CREW mode, pilot and copilot will hear entertainment input #1 while the passengers may listen to entertainment input #2.

3.6.3.2 Soft Mute and Soft Mute inhibit

The Soft Mute feature assures that the aircraft radio transmissions will not be missed due to entertainment playing. When there is radio reception or intercom conversation, the music level is dropped to a low, or background level. When the radio or intercom traffic ceases, the level gradually returns to normal.

The front panel ICS switch controls muting of entertainment source #1 (for pilot and copilot). Pushing this button places the ICS in Karaoke (or sing along) mode, which inhibits the soft mute feature. This allows the music to continue uninterrupted by intercom or radio traffic when cockpit workload is appropriate. Pushing the button again will release the mute inhibit function.

The passenger music, source #2, can be placed in the Karaoke mode if a remote switch is installed in the aircraft. See wiring information for details.

Table 3-2 Intercom Modes

Mode	Pilot Hears	Copilot Hears	Passenger Hears	Telephone	Comments
Isolate	A/C Radios Pilot Sidetone (during radio transmission) Entertainment 1 is Muted	Copilot and passenger intercom Entertainment #1	Passenger and Copilot intercom Entertainment #2	"Phone Booth" mode Pilot has exclusive use of the telephone. In TEL, Pilot & Copilot connected to Com 1 for PTT TX and receive. Others hear Tel if off hook.	This mode allows the pilot to communicate without the others bothered by the conversations. Copilot and passengers can continue to communicate and listen to music
All	Pilot Copilot A/C Radio Passengers Entertainment #1	Copilot Pilot A/C Radio Passengers Entertainment #1	Passengers Pilot Copilot A/C Radio Entertainment #2	All have access to phone through Hook Switch. Pilot access through TEL switch. All hear telephone audio if off hook.	This mode allows all on board to hear radio reception as well as communicate on the intercom. Music and intercom is muted during intercom and radio communications
Crew	Pilot Copilot A/C Radio Entertainment #1	Copilot Pilot A/C Radio Entertainment #1	Passengers Entertainment #2	Pilot and copilot don't have phone access, unless mic sel in TEL. Passengers have phone through Hook Switch, Passengers hear phone audio.	This mode allows the pilot and copilot to concentrate on flying, while the passengers can communicate amongst themselves.

3.7 Telephone Mode

The Com 3 mode can serve as a full duplex interface for telephone systems such as AirCell or portable cellular phones with earpiece jacks, if the installation is correctly configured. When interfaced with an ap-

proved airborne telecommunications system, the PMA7000B can serve as a audio control and distribution center. Each intercom position has a "hook switch." The pilot's hook switch is the "Com 3" button on the audio panel, the others are discrete switches mounted adjacent to the headset jacks. When Com 3 is active in the duplex mode, the TX button will blink about twice as fast as the normal transmit rate.

When the intercom is in **ALL** mode, the pilot can speak on the phone only if the **Com 3 is selected for transmit (Com 3 Xmt button activated)**. If any passenger places his or her switch into the "off-hook" position all passengers will also be heard on the phone. All will hear selected audio. Com 1 audio is automatically heard in the headsets. The pilot and copilot will have transmit capability on the other selected transceiver Com 1 or 2, simply by using their respective PTT switch.

In **CREW** mode, the pilot and copilot are may use the telephone, with their respective hook switch (the pilot selects Com 3 on the Xmt selector). Any passenger who places their switch into the off-hook position will also have access to the phone, and all four passengers will hear the conversation.

In **ISO** intercom mode, when the PMA7000B is in the **Com 3** mode, the pilot position is in the "Phone Booth." Only the pilot will hear the telephone, and only he will be heard. He will also have access to Com 1 or 2, and will transmit on that radio using the PTT. All selected audio is provided. If any other passenger goes "off hook" they will hear the phone.

Note: Because the cellphone uses an intercom circuit, all stations on that circuit will lose intercom capability when the cellphone is in use.

3.8 Marker Beacon Operation (If present)

The optional Marker Beacon Receiver uses visual and audio indicators to alert you when the aircraft passes over a 75 MHz transmitter.

The Blue lamp, labeled "O," is the Outer Marker lamp and has an associated 400 Hertz 'dash' tone. The lamp and tone will be keyed at a rate of two tones/flushes per second when the aircraft is in the range of the Outer Marker Beacon.

The Amber lamp, labeled "M," is the Middle Marker lamp and is coupled with a 1300 Hertz tone. It is keyed alternately with short 'dot' and long 'dash' bursts at 95 combinations per minute.

The White lamp, labeled "I," is the Inner marker and has a 3000 Hertz 'dot' tone. The lamp and tone will be keyed at a rate of six times per second.

The audio from the Marker Beacon Receiver can be heard by selecting the "MKR" push-button switch. To adjust the volume level, there is a service adjustment located on the top of the unit.

A three-position switch is used to set the receiver sensitivity and to test the indicator lamps. Use "**HI**" sensitivity initially. This allows you to hear the outer marker beacon about a mile out. Then select the "**LO**" sensitivity to give you a more accurate location of the Outer Marker. The momentary down switch position is marker test, labeled "T/M" and illuminates all three lamps simultaneously to assure the lamps (internal and external) are in working order. TST does not activate MM sense output.

Pressing the marker mode select down (to "T/M") will cause the marker audio to mute for that beacon. The next beacon received will re-activate the audio.

3.9 Internal Recorder System (Option 1, 7)

The Intercom Recording System is a digital recording system allowing automatic storage and playback of aircraft radio traffic.

Operating as a continuous loop recorder, (first message received will be the last heard), the recorder has one minute of recording time or up to 16 messages. With its own built in VOX circuit, there are no buttons to press to start recording. The system automatically begins to record the instant the radio becomes active. Only aircraft radio audio in pilots headset is recorded and only the pilot will hear the playback audio.

3.9.1 Operation

Recording is automatic; there is no action required by the pilot. To play back the last recorded message, simply press the momentary switch associated with the IRS. Each additional press of the button will play

the preceding recorded message. You must wait for the message to finish playing before accessing the prior message. To cancel the playback, press and hold the playback button for two seconds. The next time the button is pressed, the next earlier message will be heard.

3.10 Audio Messaging system (Option 1)

When this option is installed, the PMA7000B contains six stored messages. An outside annunciator, such as an Electronics International engine gage system triggers these messages. When there is an announcement, it will be repeated every two seconds until the remote-mounted ACK button is pushed. This stops the played annunciation, until the next announcement is required (the next falling edge).

3.10.1 Concurrent Messages

When a recorded message or audio annunciation is playing, the other audio source is momentarily inhibited. For instance, if an IRS message is being played, the audio annunciation will not begin until the IRS message is finished. Conversely, the IRS recording cannot be played as long as there is an aural alert being played. There is no recording made if playing a recording or annunciation.

Section IV- Warranty and Service

4.1 Warranty

In order for the factory warranty to be valid, the installations in a certified aircraft must be accomplished by an FAA-(or other ICAO agency) certified avionics shop and authorized PS Engineering dealer. If the unit is being installed by a non-certified individual in an experimental aircraft, a factory-made intercom harness must be used for the warranty to be valid.

PS Engineering, Inc. warrants this product to be free from defect in material and workmanship for a period of three (3) years from the date of installation as recorded in aircraft logbook and/or on FAA Form 337. During the first **twelve (12) months** of the three-year warranty period, PS Engineering, Inc., at its option, will send a replacement unit at our expense if the unit should be determined to be defective after consultation with a factory technician. For the remaining **twenty-four (24) months** of the three-year warranty period, the unit must be returned to PS Engineering, Inc., or an authorized warranty service facility, for no-cost repair.

All transportation charges for returning the defective units are the responsibility of the purchaser. All domestic transportation charges for returning the exchange or repaired unit to the purchaser will be borne by PS Engineering, Inc. The risk of loss or damage to the product is borne by the party making the shipment, unless the purchaser requests a specific method of shipment. In this case, the purchaser assumes the risk of loss.

This warranty is not transferable. Any implied warranties expire at the expiration date of this warranty. PS Engineering SHALL NOT BE LIABLE FOR INCIDENTAL OR CONSEQUENTIAL DAMAGES. This warranty does not cover a defect that has resulted from improper handling, storage or preservation, or unreasonable use or maintenance as determined by us. This warranty is void if there is any attempt to disassemble this product without factory authorization. This warranty gives you specific legal rights, and you may also have other rights, which may vary from state to state. Some states do not allow the exclusion of limitation of incidental or consequential damages, so the above limitation or exclusions may not apply to you.

All items repaired or replaced under this warranty are warranted for the remainder of the original warranty period. PS Engineering, Inc. reserves the rights to make modifications or improvements to the product without obligation to perform like modifications or improvements to previously manufactured products.

4.2 Factory Service

The units are covered by a three-year limited warranty. See warranty information. Call PS Engineering, Inc. at (865) 988-9800 before you return any unit. This will allow the service technician to provide any other suggestions for identifying the problem and recommend possible solutions.

After discussing the problem with the technician and you obtain a Return Authorization Number, ship product to:

PS Engineering, Inc.
Attn: Service Department
9800 Martel Rd
Lenoir City, TN 37772
(865) 988-9800 FAX (865) 988-6619
Email: support@ps-engineering.com

Units that arrive without an RMA number, or telephone number for a responsible contact, will be returned un-repaired. PS Engineering is not responsible for items sent via US Mail.

Appendix A External PTT Hook Up

Part of the installation includes the installation of PTT (Push To Talk) switches that allow the use of your aircraft radio for communications transmissions.

There are three possible configurations ; you must select the case that best fits your installation. NOTE: Only the person who presses their PTT switch will be heard over the radio.

CASE I

The PTT is built into the pilot and copilot yokes

Simply install the plugs from the headset into the aircraft headphone jacks. Then use the yoke mounted PTT to transmit. No other action is required.

CASE II

Built in PTT only on the pilot side only

This configuration requires a modified external PTT switch plugged into the copilot's mic jack. (See Details Below) When the copilot's PTT is depressed, this activates an internal relay that switches the mic audio to the aircraft radio from the pilot to the copilot.

Case III

No built in PTT switch at all.

Two built-in PTT must be installed, or two external, modified PTT switches will be required for both the pilot and copilot. Modifications to the PTT are required. (See details below)

Push To Talk Modifications

When received from the manufacturer, an after-market PTT switch opens the mic audio path to the "ring" connection of the PTT mic plug until the button is pressed. When the PTT is between the intercom and the headset, the intercom function will not work unless the PTT switch is depressed. A simple modification can be performed to allow proper intercom operation. NOTE: This mod does not alter normal operation.

Below are some examples of typical modifications. Contact the PTT manufacturer for more details if necessary.

Procedures For David Clark PTT

Unscrew the round black plastic cover from the jack.
Connect the joined black wires to the red wire.
Replace the round black plastic cover.

Procedures for Telex PT-200

Unscrew the round black plastic cover from the jack.
Cut the red wire in the middle of the wire.
Strip both ends of the insulation.
Solder the two ends to the ground lug to the PTT jack.
Replace the round black plastic cover.

Procedures for Telex PT-300

Unscrew the round black plastic cover from the plug jack.
Remove the heat shrink material from the joined black wires.
Solder these two wires to the lug that has a white wire already soldered to it.
Replace the round black plastic cover

Appendix B – PMA 7000B Installation Drawing

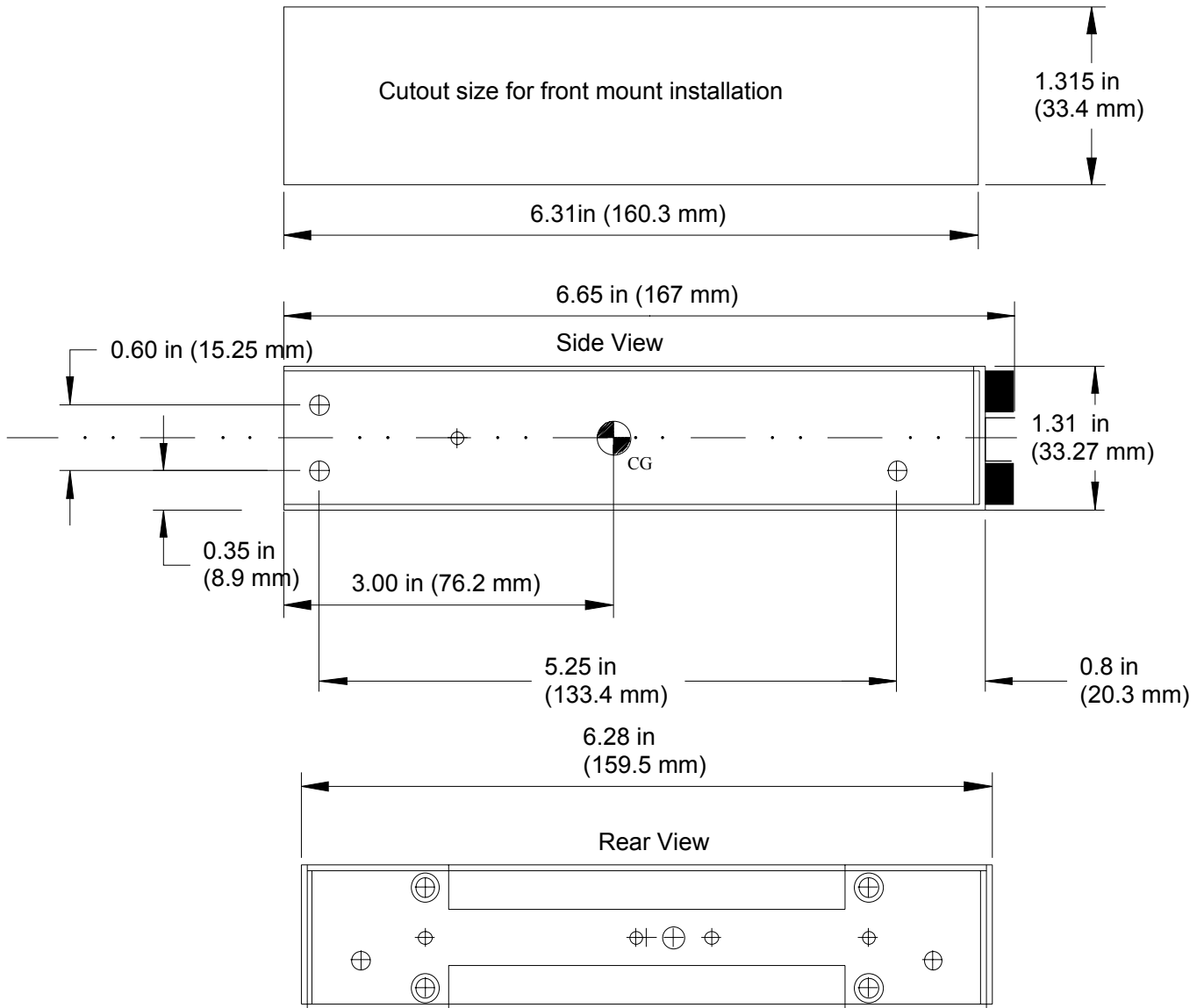

Weight: 1.5 lb with tray and connectors (.68 kg)

Connector viewed from the rear

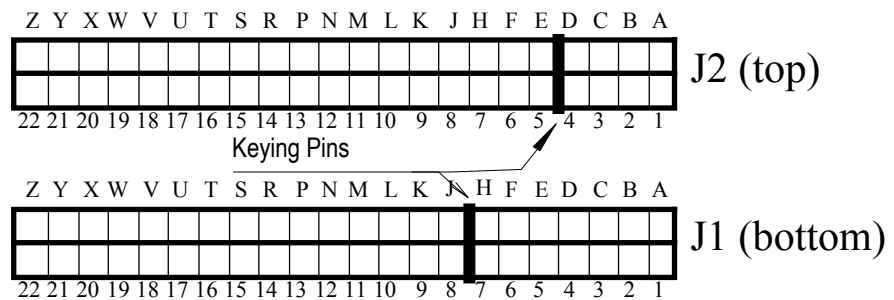

Appendix C Bottom Connector Interconnect

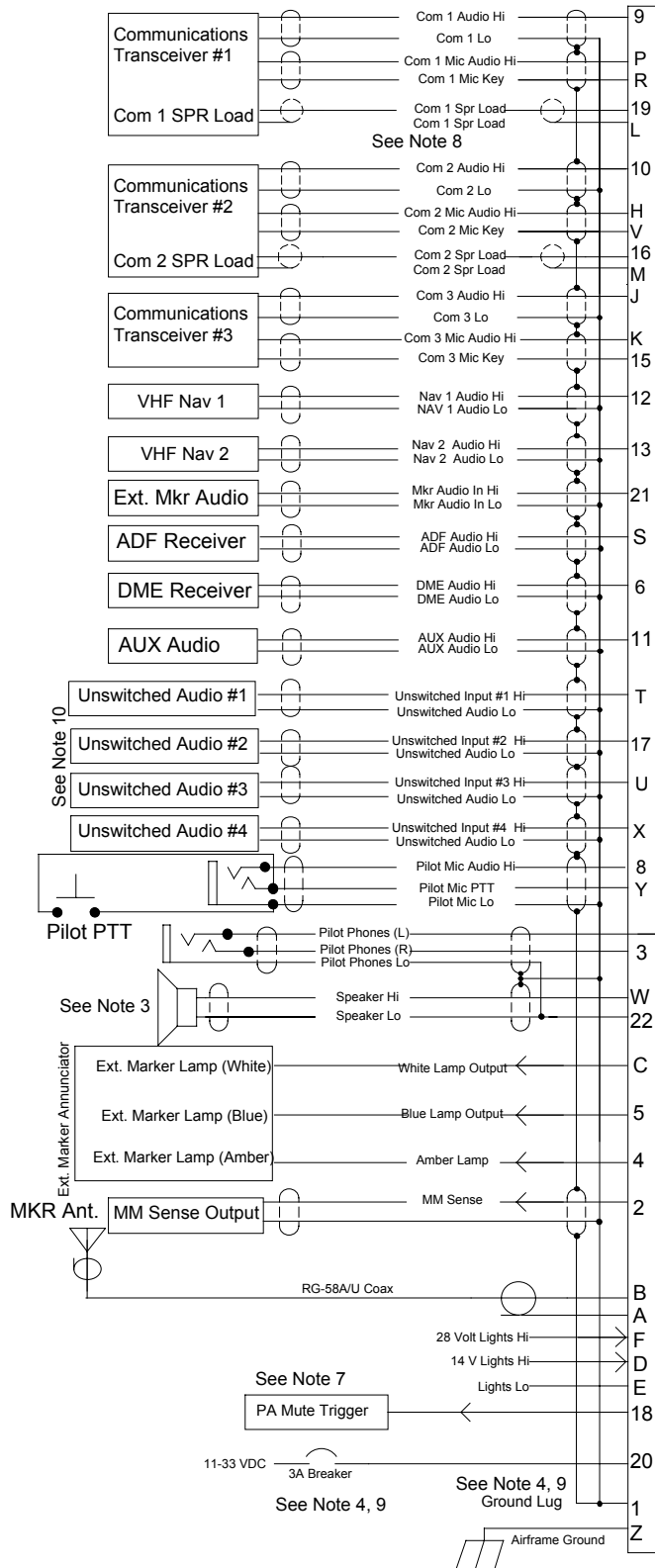

Bottom Connector, J1

Notes:

1. Pins 7, N, 14, are not used.
2. All shields should be grounded at audio panel only other end remains floating.
3. Speaker and Pilot Headphone ground returns MUST be kept separate and connected to pin 22.
4. All Power, and Ground wires must be #18 gage wire Lighting #22 AWG, other wires minimum #24 AWG
5. Pilot mic and headphone jacks must be isolated from ground.
6. Pin 20 connected through a 3 A breaker.
7. PA Mute is a TTL level logic output that is pulled low when PTT active.
8. Speaker loads may be required on some transceivers. Consult transceiver manufacturer's information.
9. Installations require a 3 A breaker. Retrofit 28V installations may remove dropping resistor and change breaker to 3A.
10. Audio applied to Pins T, 17, U and X, is always presented in speaker, pilot and copilot headphones, regardless of SPR switch or PTT.
11. All shielded wires must be MIL 22750 or 27500.
12. Connect pilot headphone (L) to top connector, Pin 1, using 3-conductor wire.
13. Key pin between pin 7 and 8.
14. External marker audio input to Pin 21 for units without internal receiver only.
15. Mic bias is not required by the PMA7000B, however, it may be left connected if present.

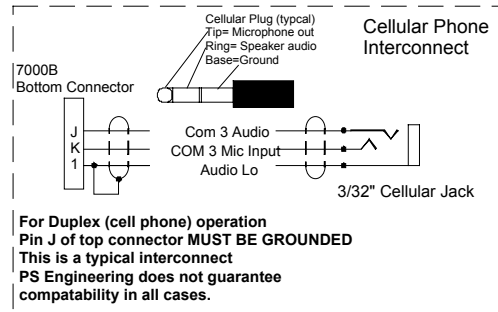

**For Duplex (cell phone) operation
Pin J of top connector MUST BE GROUNDED
This is a typical interconnect
PS Engineering does not guarantee
compatibility in all cases.**

**To Pin 1
Top Conn.**

See Note 12

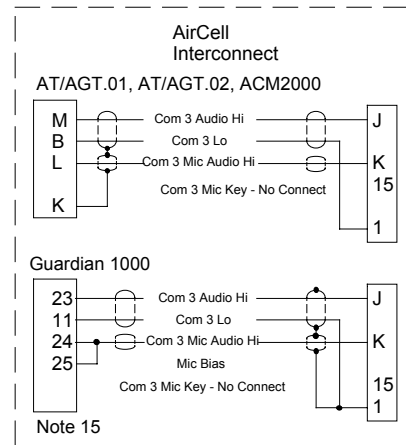

Appendix D Top Connector Interconnect

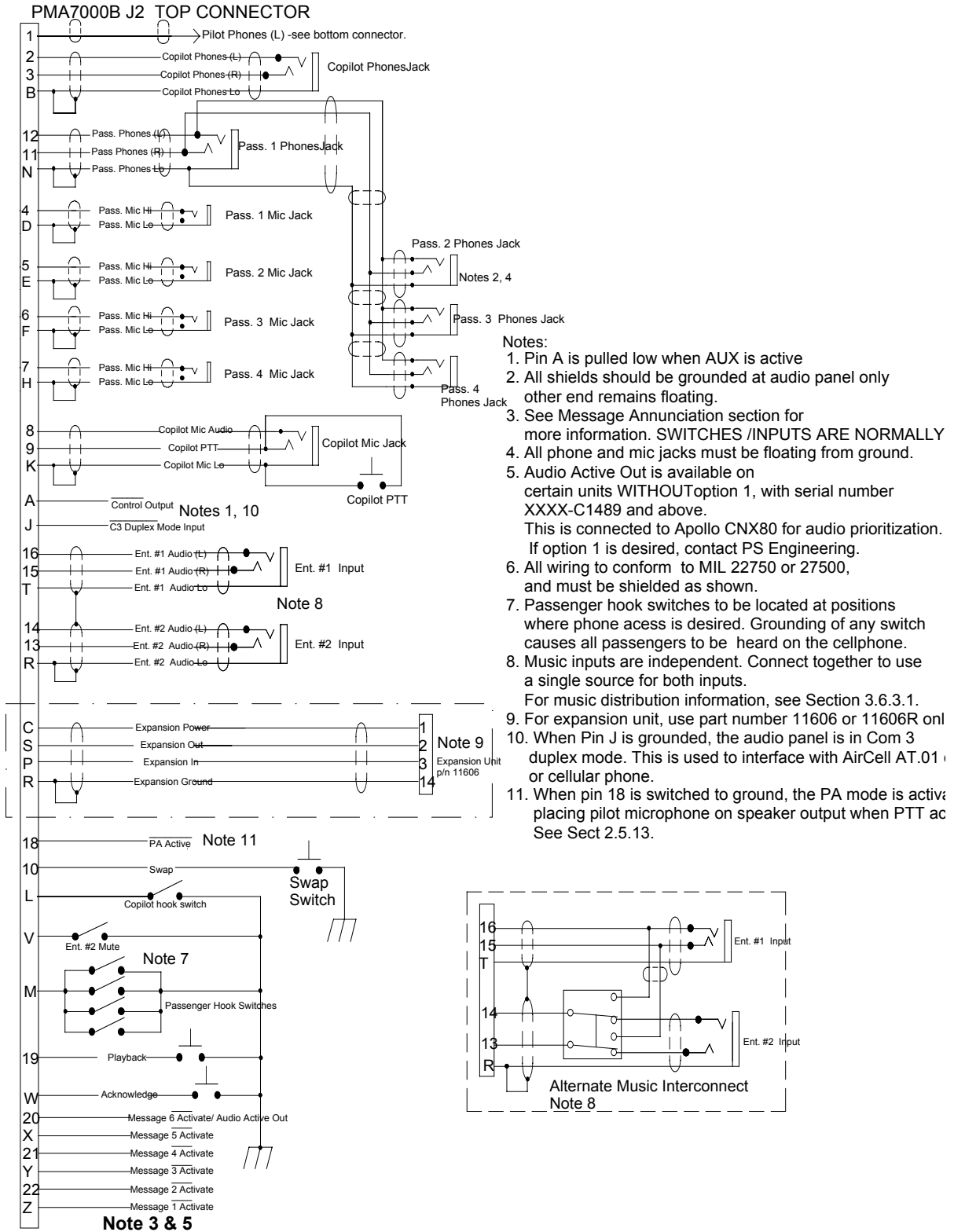

Appendix E- Instructions for FAA Form 337 and continuing airworthiness

9.1 Instructions for FAA Form 337, Audio Panels

One method of airworthiness approval is through an FAA Form 337, *Major Repair and Alteration (Airframe, Powerplant, Propeller, or Appliance)* In the case of the PMA7000B, you may use the following text as a guide.

Installed audio selector and 6-place intercom, PS Engineering PMA7000B, part number 7000 (X) in (location) at station _____. Installed per *AC43.13-2, Chapter 2, paragraph 23* (Instrument Panel Mounting). Installed per PS Engineering *Installation Operators Manual* p/n 200-780-(XXXX), revision (), dated ().

These units are FAA-Approved under TSO C50c for audio amplifiers, and/or TSO C35d for Marker Beacon Receivers, and meets appropriate environmental qualifications outlined in RTCA DO-160D as appropriate or this aircraft.

Interface to existing aircraft radios in accordance with installation manual and in compliance with practices listed in *AC43.13-2, Chapter 2*. All wires are Mil-Spec 22759 or 27500. Connection to aircraft dimmer bus is _____. Power is supplied to the unit through a 3A circuit breaker (type and part number), and total electrical load does not exceed ____% of the electrical system capacity with the PMA7000B added.

Aircraft equipment list, weights and balance amended. Compass compensation checked. A copy of the operation instructions, contained in PS Engineering document 200-780-(), revision (), dated (), is placed in the aircraft records. All work accomplished listed on Work Order _____.

9.2 Instructions for Continuing Airworthiness, Audio System

Sample ICA Checklist for PS Engineering Audio System:

Section	Item	Information
1	Introduction	Installation of audio control panel with integrated marker beacon receiver and intercommunications system.
2	Description	Installation as described in manufacturer's installation manual referenced on FAA Form 337, including interface with other avionics audio as required.
3	Controls	See installation and operator's guide referenced on FAA Form 337.
4	Servicing	None Required
5	Maintenance Instructions	On Condition, no special instructions
6	Troubleshooting	In the event of a unit problem, place the unit into "off" "fail-safe" and/or "emergency" mode. This allows pilot communications using COM 1. Follow checkout instructions in the installation manual referenced on the FAA Form 337. For a specific unit fault, contact the manufacturer at (865) 988-9800 for special instructions.
7	Removal and replacement information	<u>Removal:</u> Using a 3/32" Allen-head wrench, carefully unscrew the locking screw located in the center of the unit. While turning the wrench CCW, gently pull on the EDGES of the bezel until the unit is free from the mounting tray. <u>Installation:</u> Engage the locking screw at the back. Turn the locking screw CW, while applying slight pressure to the edges of the bezel. Do not over tighten!
8	Diagrams	Not applicable
9	Special Inspection Requirements	Not Applicable
10	Protective Treatments	Not Applicable
11	Structural Data	Not Applicable
12	Special Tools	None
13	Not Applicable	Not Applicable
14	Recommended Overhaul Periods	None
15	Airworthiness Limitations	Not Applicable
16	Revision	To be determined by installer

Appendix F RTCA DO160C (EUROCAE ED-14) Environmental Qualification Form

Audio Selector Panel/Intercom/Marker Beacon Receiver

9Part Number: 7000()

FAA TSO Number: C50c, C35d Class A, JTSO 2C35d and JTSO C50c

Manufacturer: PS Engineering Incorporated 9800 Martel Road Lenoir City TN 37772

Conditions	Section	Conducted Tests
Temperature and Altitude	4.0	Equipment tested to CAT A1 & D1
Low Temperature	4.5.1	-55° C Survival, -15°C Low Operating (A1)
High Temperature	4.5.2	+85°C Survival, +70°C High Short Time Operating
In-flight Loss of Cooling	4.5.4	Not Applicable, no cooling required
Altitude	4.6.1	50,000' unpressurized (D1)
Decompression	4.6.2	Not Applicable
Overpressure	4.6.3	Not Applicable
Temperature variation	5.2	Equipment tested to Category C
Humidity	6.0	Equipment tested to Category A
Shock	7.0	Equipment tested to Operational test only
Operational	7.2	Equipment tested to Operational test only
Crash Safety	7.3	Equipment tested to Operational test only
Vibration	8.0	Equipment tested to Category M & N
Explosion	9.0	Category X, not tested
Waterproofness	10.0	Category X, not tested
Fluids Susceptibility	11.0	Category X, not tested
Sand and Dust	12.0	Category X, not tested
Fungus	13.0	Category X, not tested
Salt Spray	14.0	Category X, not tested
Magnetic Effect	15.0	Equipment tested to Category Z
Power input	16.0	Equipment tested to Category B
Voltage Spike	17.0	Equipment tested to Category B
Audio Frequency Susceptibility	18.0	Equipment tested to Category B
Induced Frequency Susceptibility	19.0	Equipment tested to Category B
Radio Frequency Susceptibility	20.0	Equipment tested to Category T
Radio Frequency Emission	21.0	Equipment tested to Category B
Lightning Induced Transient Susceptibility	22.0	Equipment tested to Category K
Lightning Direct Effects	23.0	Category X, not tested
Icing	24.0	Category X, not tested

PS Engineering
PMA7000B Audio Selector Panel and Intercom System
Installation and Operator's Manual

Cross reference for Bendix/King KMA26

KMA26 PMA7000B			KMA26 PMA7000B		
P261	Bottom Top	Function	P262	Bottom Top	Function
1	20	Aircraft Power	1	N/C	Reserved
2	Z	Power Ground	2		16 Music 1 L Hi
3	F	28 V Lighting	3		15 Music 1 R Hi
4	9	Com 1 Audio Hi	4	Y	Pilot Mic Key
5	10	Com 2 Audio Hi	5		9 Copilot Mic Key
6	J	Com 3 Audio Hi	6	8	Pilot Mic Audio Hi
7	12	Nav 1 Audio Hi	7		8 Copilot Mic Audio Hi
8	13	Nav 2 Audio Hi	8	N/C	Key ICS Enable
9	S	ADF Audio Hi	9	3	Pilot Phone Audio Hi (R)
10	6	DME Audio Hi	10		3 Copilot Phone Audio Hi (R)
11	11	AUX Audio Hi	11	N/C	ICS Tie Hi
12	N/C	Muted Audio 1 Hi	12	W	Cabin Spr Hi
13	N/C	Muted Audio 2 Hi	13	N/C	PA SPR Hi
14	T	Unmuted Audio 1 Hi	14	5	Outer MKR Lamp Out
15	17	Unmuted Audio 2 Hi	15	4	Middle MKR Lamp out
16	U	Unmuted Audio 3 Hi	16	A	MKR ANT Shield
17	N/C	Spare	17	B	MKR ANT Center
18	N/C	Key Disable	18		R Music 2 Lo
19	N/C	Spare	19		T Music 1 Lo
20	N/C	Spare	20	N/C	Pilot ICS PTT
21	1	Com 1 Audio Lo	21	N/C	Copilot ICS PTT
22	1	Com 2 Audio Lo	22		4 Pass 1 Mic Aud Hi
23	1	Com 3 Audio Lo	23		5 Pass 2 Mic Aud Hi
24	1	Nav 1 Audio Lo	24	N/C	Reserved
25	1	Nav 2 Audio Lo	25		11 Pass 1 Phones R Hi
26	1	ADF Audio Lo	26		11 Pass 2 Phones R Hi
27	1	DME Audio Lo	27	N/C	ICS Tie Lo
28	1	AUX Audio Lo	28	18	PA Mute
29	N/C	Muted Audio 1 Lo	29	22	Speaker Audio Lo
30	N/C	Muted Audio 2 Lo	30	N/C	PA SPR Lo
31	1	Unmuted Audio 1 Lo	31	C	Inner MKR Lamp Out
32	1	Unmuted Audio 2 Lo	32	2	MM Sense out
33	1	Unmuted Audio 3 Lo	33	N/C	Reserved
34	1	Chassis Ground	34		14 Music 2 Left Hi

PS Engineering
PMA7000B Audio Selector Panel and Intercom System
Installation and Operator's Manual

P261	Bottom	Top	Function	P262	Bottom	Top	Function
35	D		14 V Lights	35		13	Music 2 Right Hi
36		J	Com 3 Hot Mic Enable	36	N/C		Pass ICS Key
37	P		Com 1 Mic Audio Hi	37	N/C		Pass ICS Key
38	R		Com 1 Mic Key	38		6	Pass 3 Mic Aud Hi
39	H		Com 2 Mic Audio Hi	39		7	Pass 4 Mic Aud Hi
40	V		Com 2 Mic Key	40	N/C		Ground
41	K		Com 3 Mic Audio Hi	41		11	Pass 3 Phones R Hi
42	15		Com 3 Mic Key	42		11	Pass 4 Phones R Hi
43	19		Com 1 SPR Load Hi	43	N/C		Pass ICS Tie
44	L		Com 1 SPR Load Lo	44	N/C		Pass ICS Tie
45	16		Com 2 SPR Load Hi	45	N/C		CVR Audio Out Hi
46	M		Com 2 SPR Load Lo	46	N/C		CVR Audio Out Lo
47	X		Unmuted Audio 4 Hi	47	N/C		MKR Audio Out Hi
48	1		Unmuted Audio 4 Lo	48	N/C		MKR Audio Out Lo
49	N/C		Spare	49	20		MKR SPR Power
50		V	Music Mute Enable	50	Z		Power Ground

This information is for reference only. PS Engineering, Inc. does not make assertion that the cross reference is accurate or complete for all installations. Consult the manufacturer's installation manuals

KMA26			PMA7000B		
N/C			1	Pilot Phones Hi (L)	
N/C			2	Copilot Phones Hi (L)	
N/C			12	Pass Phones Hi (L)	
N/C			10	SWAP (Optional)	
3				Remove for 14 V lighting	
N/C		L		Copilot Hook Switch (opt)	
N/C		M		Pass Hook Switch (opt)	
N/C		V		Ent. #2 mute inhibit	
N/C	N/C			AirCell Tip	
N/C	N/C			AirCell Ring	

Cross-reference for GMA340

GMA340		PMA7000B		GMA340		PMA7000B	
J1	Function	J1	J2	J2	Function	J1	J2
1	Mkr Ant	B		1	Pilot Phones Lo	1	
2	Mkr Ant Lo	A		2	Copilot Phn Lo		B
3	Com 3 Audio in	J		3	Copilot Phn (L)		3
4	Com 3 Lo	1*		4	Copilot Phn (R)		2
5	Com 3 Mic Audio	K		5	Lights lo	E	
6	Com 3 Mic Key	15		6	14/28 V Lights	F	
7	ADF Audio In	S		7	14/28 V Lights	D	
8	ADF Audio Lo	1*		8	Aircraft Power	20	
9	Com 1 Audio	9		9	Aircraft Power	20	
10	Com 1 Audio Lo	1		10	Aircraft Ground	Z	
11	Com 1 Mic	P		11	Aircraft Ground	Z	
12	Com 1 Mic Key	R		12	PA Mute	18	
13	Com 2 Audio	10		13	Mute Inhibit		V
14	Com 2 Audio Lo	1		14	Mute Inhibit Lo	Z	
15	Com 2 Mic	H		15	No Connect		
16	MASQ	U		16	Pilot Phones (L)	3	
17	Nav 1 Audio	12		17	8 ohm select	n/c	
18	Nav 1 Audio Lo	1		18	Reserved		
19	Nav 2 Audio	13		19	Tone Enable	n/c	
20	Nav 2 Audio Lo	1		20	Swap		10
21	DME Audio	6		21	Swap Lo		Z
22	DME Audio Lo	1		22	No Connect		
23	Com 3 Spkr Load	n/c		23	Music 1 (L)		15
24	Com 3 Spkr Load	n/c		24	Music 1 (R)		16
25	Com 1 Speaker Load	19		25	Music 1 Lo		T
26	Com 1 Speaker Load	L		26	Music 2 (L)		13
27	Com 2 Speaker Load	16		27	Music 2 (R)		14
28	Com 2 Speaker Load	M		28	Music 2 Lo		R
29	No Connect	n/c		29	No Connect		
30	Com 2 Mic Key	V		30	No Connect		
31	Unswitched Unmuted 1	T		31	Pilot Phones(Rt)		1
32	Unswitched Lo	1		32	Copilot Mic Audio		8
33	Pilot Mic Audio	8		33	Copilot Mic PTT		9
34	Pilot Mic PTT	Y		34	Copilot Mic Lo		K
35	Pilot Mic Lo	1		35	Pass 1 Mic Audio		4
36	Ext IM MKR	C		36	Pass 1 Mic Lo		D
37	Ext OM MKR	5		37	Pass 2 Mic Audio		5
38	Ext MM MKR	4		38	Pass 2 Mic Lo		E
39	MM Sense	2		39	Pass 3 Mic Audio		6
40	Pass HP (L)		11	40	Pass 3 Mic Lo		F
41	Pass HP (R)		12	41	Pass 4 Mic Audio		7
42	Pass HP Lo		N	42	Pass 4 Mic Lo		H
43	Unswitched 2 Lo	1		43	Speaker Lo	22	
44	Unswitched 2 Audio	17		44	Speaker Output	W	